

MAYOR OF LONDON

---

THE LONDON CURRICULUM  
BIOLOGY KEY STAGE 3

# THE LIVING RIVER

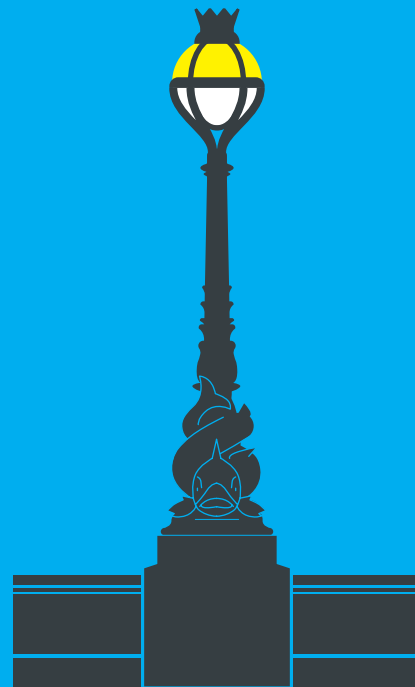

# THE LONDON CURRICULUM

## PLACING LONDON AT THE HEART OF LEARNING

The capital is the home of innovations, events, institutions and great works that have extended the scope of every subject on the school curriculum. London lends itself to learning unlike anywhere else in the world. The London Curriculum aims to bring the national curriculum to life inspired by the city, its people, places and heritage.

To find out about the full range of free resources and events available to London secondary schools at key stage 3 please go to [www.london.gov.uk/london-curriculum](http://www.london.gov.uk/london-curriculum).

## STEM in the London Curriculum

London provides numerous historical and contemporary cutting edge examples of scientists, engineers and mathematicians who have worked in their fields to create innovative solutions to problems throughout the world. Population growth, trade, communication, transport, health, food, water supply and many other aspects of life in London have driven technology-based innovations. London Curriculum science, maths, design & technology teaching resources aim to support teachers in helping their students to:

- ◆ **DISCOVER** the application of their subject knowledge to the life of the city.
- ◆ **EXPLORE** their neighbourhood and key sites around London, learning outside the classroom to see and understand how STEM subjects have shaped many aspects of the city.
- ◆ **CONNECT** their learning inside and outside the classroom, analysing situations and using their subject knowledge to create and present solutions.



## CONTENTS

<b>OVERVIEW</b>	2	Resource 2.6: Predator-prey graph	37	<b>EXPLORE</b>	60
<b>DISCOVER</b>	5	Resource 2.7: Predator-prey graph statements	38	<b>Lesson 4: London river life</b>	61
<b>Lesson 1: What is living here now and what was living here before?</b>	6	Resource 2.8: Symbiosis/Parasitism example	39	Activities	65
Activities	10	Resource 2.9: Table template	41	Resource 4.1: Success criteria for a scientific poster	67
Resource 1.1: How does toxicity build up in the food chain? –Storyboard	13	Resource 2.10: Pyramids of number and biomass models	42	Resource 4.2: A, B and C scientific poster templates	68
Resource 1.2: How does toxicity build up in the food chain? – Storyboard with support	14	Resource 2.11: Pyramids of number and biomass construction	44	<b>CONNECT</b>	73
Resource 1.3: When was it like that?	15	<b>Lesson 3: Taking a closer look</b>	45	<b>Lesson 5: What's living here?</b>	74
Resource 1.4: Why is treating sewage important? – Writing frame	21	Activities	48	Activities	75
Resource 1.5: Why is treating sewage important? – Success criteria	22	Resource 3.1: How a microscope works	51	Resource 5.1: Suggested success criteria	76
<b>Lesson 2: If I live here, will you live here too?</b>	23	Resource 3.2: Magnification practice	52	Links to other London Curriculum subjects	77
Activities	26	Resource 3.3: Microscope drawings – Success criteria	53	Credits	78
Resource 2.1: Thames' food chains	30	Resource 3.4: List of suggested pre-prepared slides to use	54		
Resource 2.2: Interdependence questions	33	Resource 3.5: Microscope to label	56		
Resource 2.3: Thames' species information	34	Resource 3.6: Microscope to label with keywords	57		
Resource 2.4: Whales and dolphins in the Thames	35	Resource 3.7: How to prepare an Elodea slide	58		
Resource 2.5: Predator-prey role play	36	Resource 3.8: Amoeba information	59		

## LIVING RIVER OVERVIEW



RIVER THAMES & LONDON EYE  
Lewis Clarke © Wikimedia Commons

### UNIT AIMS AND ACTIVITIES

The Thames is a thriving and complex ecosystem, which has changed considerably over the years. An understanding of the impact of the environment on ecosystems (i.e. the interplay of biotic and abiotic factors) is required to understand the changing populations in the Thames. In this unit students start at the macroscopic, moving towards the microscopic, as they seek to understand what affects living things. This can then allow them to consider their own impact on the environment and how our waterways can be improved.

The purpose of this unit is to produce a flyer, leaflet, short video, podcast or poster that can be used to describe and explain what affects river ecosystems.

## KEY STAGE 3 NATIONAL CURRICULUM

This unit addresses subject content requirements within the biology part of the key stage 3 national curriculum for science on:

### Cells and organisation

- ◆ cells as the fundamental unit of living organisms, including how to observe, interpret and record cell structure using a light microscope
- ◆ the similarities and differences between plant and animal cells

### Photosynthesis

- ◆ the dependence of almost all life on Earth on the ability of photosynthetic organisms, such as plants and algae, to use sunlight in photosynthesis to build organic molecules that are an essential energy store and to maintain levels of oxygen and carbon dioxide in the atmosphere

### Relationships in an ecosystem

- ◆ the interdependence of organisms in an ecosystem, including food webs
- ◆ how organisms affect, and are affected by, their environment, including the accumulation of toxic materials

### Inheritance, chromosomes, DNA and genes

- ◆ the variation between species and between individuals of the same species means some organisms compete more successfully, which can drive natural selection
- ◆ changes in the environment may leave individuals within a species, and some entire species, less well adapted to compete successfully and reproduce, which in turn may lead to extinction

## KEY STAGE 3 NATIONAL CURRICULUM

In covering this content, this unit also addresses some of the broader aims, under working scientifically in the key stage 3 national curriculum for science, in ensuring that students:

### Scientific attitudes

- ◆ pay attention to objectivity and concern for accuracy, precision, repeatability and reproducibility
- ◆ understand that scientific methods and theories develop as earlier explanations are modified to take account of new evidence and ideas, together with the importance of publishing results and peer review

### Experimental skills and investigations

- ◆ ask questions and develop a line of enquiry based on observations of the real world, alongside prior knowledge and experience
- ◆ use appropriate techniques, apparatus, and materials during fieldwork and laboratory work, paying attention to health and safety
- ◆ make and record observations and measurements using a range of methods for different investigations; and evaluate the reliability of methods and suggest possible improvements
- ◆ apply sampling techniques

### Analysis and evaluation

- ◆ apply mathematical concepts and calculate results
- ◆ present observations and data using appropriate methods, including tables and graphs
- ◆ interpret observations and data, including identifying patterns and using observations, measurements and data to draw conclusions
- ◆ present reasoned explanations, including explaining data in relation to predictions and hypotheses

### Measurement

- ◆ undertake basic data analysis including simple statistical techniques

# DISCOVER

Students will look at a historical timeline of the quality of Thames' water and species living within it. They will consider how that is related to pollution levels, which effects pH and light levels. They will also go on to consider changes in temperature (linked to climate change) and how that may affect populations. In addition, students will gain an understanding of how toxicity can build up in organisms. Students will explore how organisms affect the environment and also each other through the interaction of food webs. Comparing plants and animals, students will consider interdependence including competition and predator-prey relationships. Using a microscope to look at animal and plant cells, students will prepare simple slides and draw scale diagrams.



## LESSON 1

# WHAT IS LIVING HERE NOW, AND WHAT WAS LIVING HERE BEFORE?



### THE BIG IDEA

Environmental conditions (abiotic factors) effect on organisms in an ecosystem (biotic factors), including pH and temperature.



### LEARNING OUTCOMES

Could describe the impact of increasing levels of greenhouse gases on the Thames' ecosystem.

Should describe the impact of pollution on the Thames' ecosystem.

Must understand what conditions living things need to survive (such as oxygen levels, pH, light etc).

Must describe how toxicity builds up in a food chain.



### RESOURCES

**Resource 1.1:** How does toxicity build up in a food chain? – Storyboard

**Resource 1.2:** How does toxicity build up in a food chain? – Storyboard with support

**Resource 1.3:** When was it like that?

**Resource 1.4:** Why is treating sewage important? – Writing frame

**Resource 1.5:** Why is treating sewage important? – Success criteria



## LESSON 1

# WHAT IS LIVING HERE NOW, AND WHAT WAS LIVING HERE BEFORE?



### YOU WILL ALSO NEED

- ◆ 10 small beakers
- ◆ Beads of two colours (at least 50 in total, ratio of 4:1)
- ◆ 1 bigger beaker

### MATHEMATICAL SKILLS

- ◆ Number line
- ◆ Multiplication

### KEYWORDS

- ◆ pH
- ◆ Temperature
- ◆ Greenhouse effect
- ◆ Global warming
- ◆ Climate change
- ◆ Ecosystem
- ◆ Organism
- ◆ Toxin
- ◆ Poison
- ◆ Toxicity
- ◆ Bioaccumulation

## LESSON 1: WHAT IS LIVING HERE NOW, AND WHAT WAS LIVING HERE BEFORE?

### SETTING THE SCENE



THE 'SILENT HIGHWAY' - MAN  
*YOUR MONEY OR YOUR LIFE*, 1858

John Leech © Museum of London

A cartoon published in PUNCH magazine, 10 July 1858. The allegorical figure of death rows a boat on the polluted River Thames, as dead animals float by. This cartoon refers to the problems caused by 'The Great Stink' in the summer of 1858.

#### Rubbish and waste

Since medieval times, pollution of the Thames has been a problem as Londoners threw their rubbish into it. During the Industrial Revolution, the growth of factories and the population led to problems from industrial waste and overflowing cesspits. After cesspits were abolished in the 1840s, all new houses, often with water-closets, were plumbed into the old drainage system. This had been designed to carry just rainwater but transported the excrement and waste of over two million Londoners and turned the Thames into a giant sewer. By 1849 fish had disappeared from the tidal Thames. However people were still drinking water that was taken from the Thames. In 1853 contaminated water caused a cholera outbreak that spread through London and killed thousands of people. In 1858, a heat wave caused a disgusting smell to arise from the Thames. It caused uproar in the Houses of Parliament, known as 'The Great Stink'. It led to action being taken and a new network of sewers proposed by Joseph Bazalgette was made a reality. However

these were damaged in the second world war, and in 1957 the Thames was declared 'biologically dead'.

#### Back from the dead

Since then an incredible amount of work has been done to rebuild the sewage systems and improve water quality. Today, the River Thames is the cleanest river flowing through a major city in the world. It is home to 125 species of fish and 400 species of invertebrates live on the muddy river banks. This transformation was the result of conservation efforts, legislation and infrastructure improvements. The River Thames is teeming with life. In 2016 the building of a 'super sewer', the Thames Tidal Tunnel is planned to begin. This 25km tunnel will not be completed till 2020, or later. (A comprehensive history of the Thames, including key dates in relation to biology, can be found in the Thames Barrier Resource Pack, see 'Further Reading' section for more details).

## JOSEPH BAZALGETTE (1819 – 1891)

Joseph Bazalgette was born in 1819 in London. He was originally a railway engineer but in 1842 he set up his own practice and was approached to take on different types of engineering projects across the country. He also trained other civil engineers. Some of his work was for cities overseas, including as far away as Mauritius as well as countries in Europe. He became the chief engineer of London's Metropolitan Board of Works, after it was set up in 1856. The board was the first organisation to supervise public works coordinated across London.

Due to the 'Great Stink' in 1858, legislation was passed by Parliament enabling the Metropolitan Board to raise money to build a new sanitation system. By 1866 most of London was connected to a sewer network devised by Bazalgette (in collaboration with William Hayward). The sewers are partially hidden by large embankments, including the Albert and Victoria Embankments, which were completed by 1870. The Victoria Embankment protected Bazalgette's low-level sewer as well as the District Railway underground. These embankments turned what was a tidal mud shore in to land on which roads and gardens could be built. The Chelsea Embankment was completed in 1874, with over 52 acres of land being made usable from it's completion. Two additional sewers were added to the network in 1910.

Bazalgette died in 1891. In 1901 a memorial to him was put on display near where Embankment station now is.

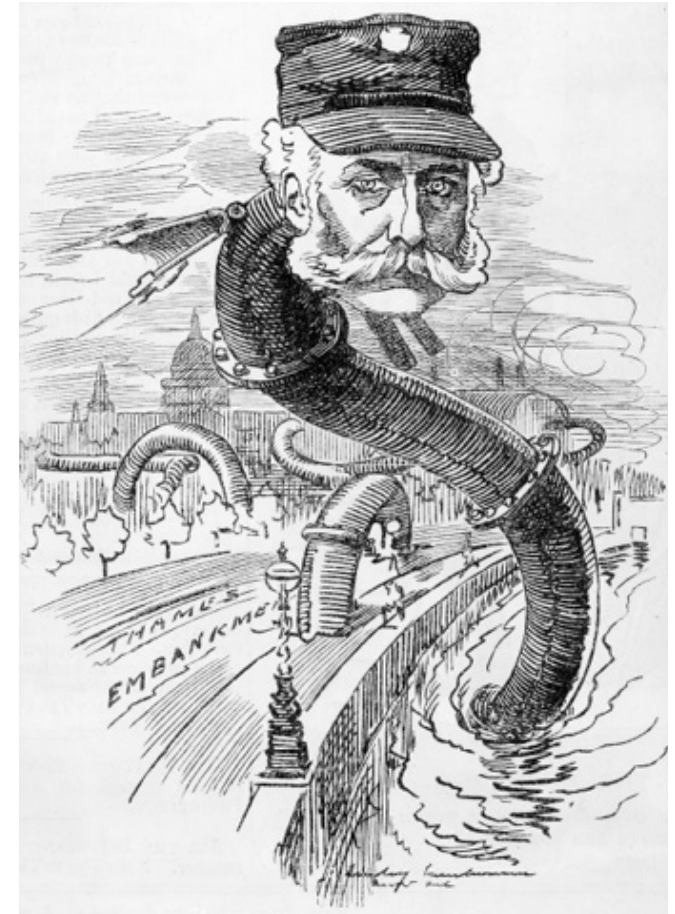

PORTRAIT OF SIR JOSEPH BAZAGETTE (1819–1891)  
Punch © Wellcome Library London

## LESSON 1: WHAT IS LIVING HERE NOW, AND WHAT WAS LIVING HERE BEFORE?

### ACTIVITIES

#### STARTER: TOXIC BUILD-UP

Demonstrate to students how toxicity builds up in a food chain. Have 10 small beakers and a jar of beads with 2 colours (with less of one colour which will represent the toxin; a ratio of 4:1 is ideal). Explain that the jar is the food for some small fish and it has been contaminated by some poison. Into each small beaker move in some beads, taking roughly 4 of the uncontaminated colour and 1 of the contaminated colour. Ask students why they think these small fish may survive despite the poison, to get them to think that there may not be enough to kill them off immediately. Then take a bigger beaker to represent a bird or a bigger fish, which is going to feed on the small fish. Take 5 of the small beakers and pour them in to the bigger beaker. Ask students to describe what has happened. Ask them why the poison may now cause a problem, to get them to identify it has built up.

Students then complete a storyboard, Resource 1.1 (page 13) or Resource 1.2 (page 14) to describe toxicity build up in a food chain/web.

#### Differentiation

To support students, some key words can be provided. To support students further a storyboard with sentence starters can be provided, Resource 1.2 (page 14).

#### MAIN 1: CAN YOU LIVE IN THIS?

Ask students how they think the Thames may have changed over time. Draw out ideas about pollution. They may have seen some recent news about pollution (see 'Further reading'). Ask them to think about what effect pollution has on water, including availability of light, oxygen and pH.

Give students a card sort with years and descriptions of key events related to the Thames and what was living in the Thames and get them to match it up, Resource 1.3 (pages 15 – 20). This can provide a basis for discussing the current quality of the water in the River Thames' and how improvements and problems have occurred through human actions.

#### MAIN 2: IT'S GETTING HOT IN HERE

Get students to discuss in pairs what effects they think increasing levels of greenhouse gases would have on the river, and use this to gather ideas from the class. They should at least be able to describe effects due to global warming, or climate change. These should include both the temperature and water level. Get students to decide what changes they think will happen in the Thames ecosystem after 20 years' time. Ensure they think about aquatic plants and algae (relating changes to levels of sunlight and temperature).

#### Differentiation

Students can think about how raised levels of carbon dioxide could positively affect plant and algae populations and also the negative effects it could have through lower pH, and the effect that would then be had on other organisms.

## PLENARY

Linking back to the historical context, a big difference was made in having treated sewage works. Students imagine they are an environmental scientist working in their local area. The local sewage works is currently getting the view of locals about treating the sewage. Some locals have complained that it is very expensive and a waste of money. Students write in to the local newspaper to describe and explain why treating the sewage is important. Suggested success criteria to be shared with students, Resource 1.5 (page 22).

### Differentiation

To extend students get them to include links to key historical facts in their letter, Resource 1.3 (pages 15 – 20). Students may also include the idea of toxin build up.

To support students provide them with a writing frame, Resource 1.4 (page 21). Key words can also be shared.

### Homework idea

Students investigate a particular Thames species and develop a personal time-line or article about its population size and what caused changes at different times. An easy choice would be salmon. They could also look at eels, which are currently declining but reasons are unclear.

## Assessment questions

Adapt or extend questions based on activities, and/or use the following examples:

1. What conditions do plants need to thrive in the River Thames?
2. What conditions do animals need to thrive in the River Thames?
3. How does toxicity build up in food chains?
4. What key events in human history (e.g. Industrial Revolution, increased population) have had a negative impact on the River Thames?  
**Extension:** Could the negative impact have been prevented? If so, how?
5. What actions have humans taken to improve the River Thames'?
6. What impact do you think climate change will have on the River Thames?  
**Extension:** Could any negative impact be prevented? If so, how?
7. What actions could you/we take in the future to improve the River Thames?

## Further reading

Thames Barrier resource pack

[bit.ly/1HQcP6I](https://bit.ly/1HQcP6I)

Please refer to the terms and conditions for use of the Thames Barrier resource pack:

[bit.ly/1Hecpn9](https://bit.ly/1Hecpn9)

Check local water quality at wildswimming.co.uk:

[bit.ly/1dA5zjb](https://bit.ly/1dA5zjb)

Thames Water guide to the sewage treatment process:

[bit.ly/1rBW2u4](https://bit.ly/1rBW2u4)

Article in The Telegraph about the clean-up of the River Thames:

[bit.ly/1JzUWeE](https://bit.ly/1JzUWeE)

Thames tideway tunnel, for sewage, being built from 2016:

[bit.ly/1wi96Hn](https://bit.ly/1wi96Hn)

## Sources and further reading on Joseph Bazalgette

sciencemuseum.org.uk:

[bit.ly/1oDfuqq](https://bit.ly/1oDfuqq)

bbc.co.uk/history:

[bbc.in/1DucZeB](https://bbc.in/1DucZeB)

history.co.uk:

[bit.ly/1C2wCiC](https://bit.ly/1C2wCiC)

pmj.bmj.com:

[bit.ly/1NzgQ0j](https://bit.ly/1NzgQ0j)

## Careers in environmental science

Job prospects that require an environmental science degree at prospects.ac.uk:

[bit.ly/1dA5BYr](https://bit.ly/1dA5BYr)

Introduction to environmental science careers at futuremorph.org:

[bit.ly/1C2wKii](https://bit.ly/1C2wKii)

futuremorph.co.uk case study of Carolyn Roberts – water resource scientist:

[bit.ly/1LFN7n9](https://bit.ly/1LFN7n9)

futuremorph.co.uk case study of Jon Bridge – soil scientist:

[bit.ly/1C2wOP8](https://bit.ly/1C2wOP8)

## STEM careers relating to Thames tideway tunnel

futuremorph.co.uk case study of Patricia Tumwine – Environmental impact assessment coordinator:

[bit.ly/1HypNG4](https://bit.ly/1HypNG4)

## Careers at Thames Water (some of which involve STEM)

[bit.ly/1emIUZs](https://bit.ly/1emIUZs)

LESSON 1: WHAT IS LIVING HERE NOW, AND WHAT WAS LIVING HERE BEFORE?

RESOURCE 1.1: HOW DOES TOXICITY BUILD UP IN A FOOD CHAIN?



Describe and explain using both pictures and words.

## LESSON 1: WHAT IS LIVING HERE NOW, AND WHAT WAS LIVING HERE BEFORE?

### RESOURCE 1.2: HOW DOES TOXICITY BUILD UP IN A FOOD CHAIN?



Describe and explain using both pictures and words.

Toxic materials are poisonous. Some quickly break down into harmless substances. Others are persistent.	When some small fish...	If the toxin does not break down...
When a bigger fish or a bird eats...	In the bigger fish or bird there is now...	This results in....



## LESSON 1: WHAT IS LIVING HERE NOW, AND WHAT WAS LIVING HERE BEFORE?



### RESOURCE 1.3: WHEN WAS IT LIKE THAT?

Here the time and descriptions of events and the state of the River Thames are displayed in the correct order. To use with students, copy and cut up to create a card sort.

PRE-15TH CENTURY	1787
Fish, including salmon were plentiful in the River Thames, which was clean. Salmon was regularly fished and a cheap food source.	On the 1st January a very ill, but still alive, shark was found by fishermen near Poplar. The shark later died and was found to have ingested a clothed person, among other things.

## LESSON 1: WHAT IS LIVING HERE NOW, AND WHAT WAS LIVING HERE BEFORE?

### RESOURCE 1.3: WHEN WAS IT LIKE THAT? CONTINUED

1833	1855	1858
<p>Last known naturally spawned salmon were caught in the Thames.</p>	<p>A letter from Michael Faraday in The Times newspaper, London, describes the polluted state of the River Thames he had observed on a boat trip:</p> <p>“The whole of the river was an opaque pale brown fluid. ...surely the river which flows for so many miles through London ought not to be allowed to become a fermenting sewer.”</p>	<p>The House of Commons is deserted. The putrid stench emanating from the river is too great for the MPs to take, despite the curtains being soaked in chloride of lime. This is The Great Stink! The water was contaminated by cholera and had already caused thousands of deaths.</p>

## LESSON 1: WHAT IS LIVING HERE NOW, AND WHAT WAS LIVING HERE BEFORE?

### RESOURCE 1.3: WHEN WAS IT LIKE THAT? CONTINUED

1866	1878	1939 – 1941
<p>The government commissioned the engineer Joseph Bazalgette to plan and construct a new sewer system. By this year, when it was completed, the new gravity powered sewers carried sewage out of Central London and discharged it further down the estuary (to be carried out to sea on the tide).</p>	<p>More than 600 passengers on the steamship Princess Alice died when the pleasure boat sank in a collision on the River Thames. As they swam towards the safety of the shore, the passengers were overcome by the noxious cocktail of pollution in the water.</p>	<p>The Thames and London's Docks suffered heavily during the Second World War. The first bombs fell on the heavily-targeted Thames. The bombing during the war caused massive damage to London's infrastructure and this combined with a large population, meant that sewage once again was discharged straight into the river.</p>

## LESSON 1: WHAT IS LIVING HERE NOW, AND WHAT WAS LIVING HERE BEFORE?

### RESOURCE 1.3: WHEN WAS IT LIKE THAT? CONTINUED

1957	Late 1950s/Early 1960s	1960s
<p>Filthy, opaque and stinking of rotten eggs: the River Thames is declared biologically dead thanks to its soaring pollution levels, resulting in levels of oxygen too low to sustain life.</p>	<p>Post-war repairs were made on the sewage system and water treatment plants were built to prevent polluted water entering the River Thames.</p>	<p>New laws were passed to stop factories discharging dirty water into the Thames.</p>

LESSON 1: WHAT IS LIVING HERE NOW, AND WHAT WAS LIVING HERE BEFORE?

RESOURCE 1.3: WHEN WAS IT LIKE THAT? CONTINUED

1974	Late 1980s/Early 1990s	1996
<p>The first salmon for 150 years was caught in the Thames, indicating a significant improvement in water quality.</p>	<p>When redeveloping the Isle of Dogs and Royal Docks, the London Docklands Development Corporation invested in new drainage infrastructure to manage future sewage.</p>	<p>The Environment Agency (EA) takes charge of regulating the Thames' water. This includes setting legislation and ensuring it is enforced. Many 'clean-up' initiatives are run by local groups, and overseen by the EA. In addition, along with local authorities, they have removed the old concrete barriers that contained the river (which prevented plant growth). Instead they have built up mud banks which allow reed beds to take hold. Piles of rubble at the side help to capture sediment, creating a habitat for invertebrates that are food for other species.</p>

## LESSON 1: WHAT IS LIVING HERE NOW, AND WHAT WAS LIVING HERE BEFORE?

### RESOURCE 1.3: WHEN WAS IT LIKE THAT? CONTINUED

2006	2014
<p>A northern bottle-nosed whale, 5 metres in length was seen in the Thames. Huge crowds gathered along the river banks to witness the very unusual event. In a very sad ending, she died as rescuers transported her on a barge towards deeper water in the Thames Estuary.</p>	<p>The number of seals spotted in the Thames Estuary has rocketed by more than 250 in the past year to a population of almost 1,000.</p>

## LESSON 1: WHAT IS LIVING HERE NOW, AND WHAT WAS LIVING HERE BEFORE?



### RESOURCE 1.4: WHY IS TREATING SEWAGE IMPORTANT? – WRITING FRAME

You are an environmental scientist working in your local area. The local sewage works is currently getting the view of locals about treating the sewage. Some locals have complained it is very expensive and a waste of money. Write in to the local newspaper to describe and explain why treating the sewage is important.

*(Name and address of newspaper)*

*(Your address)*

*(Date)*

Dear Editor,

I read your article, dated / / 'money down the drain'. I am writing to explain why actually money spent on sewage treatment is money very well spent.

Sewage contains...

When it is untreated, sewage...

The problems with this are...

The effect on fish and birds is...

In the past...

The effect on humans is...

In the past...

Sewage treatment involves...

When it is treated...

The benefits of this are...

This is important because....

I urge all local residents to support sewage treatment, for the benefit of themselves and the environment.

Yours faithfully,

*(Your name)*

Environmental Scientist

## LESSON 1: WHAT IS LIVING HERE NOW, AND WHAT WAS LIVING HERE BEFORE?

### RESOURCE 1.5: WHY IS TREATING SEWAGE IMPORTANT? – SUCCESS CRITERIA



You are an environmental scientist working in your local area. The local sewage works is currently getting the view of locals about treating the sewage. Some locals have complained it is very expensive and a waste of money. Write in to the local newspaper to describe and explain why treating the sewage is important.

#### How should your letter be set out?

Follow rules for a formal letter:

- ◆ Include your address in the top right
- ◆ Include the date underneath your address on the right
- ◆ Include the name and address of who you are writing to underneath the date, on the left
- ◆ Start the letter with “Dear Editor...”
- ◆ Begin by saying what you are writing about
- ◆ The next paragraph should describe and explain the problems with untreated sewage
- ◆ The following paragraph should describe and explain the benefits of treated sewage
- ◆ Finish by saying what you think people should do
- ◆ End the letter with “yours faithfully” (because you have not addressed it to a named person) and sign off with your name and position

#### What makes the best letter?

You are writing to persuade, so use persuasive language and devices:

- ◆ Rhetorical questions
- ◆ Emotive language
- ◆ Parallel structures
- ◆ Sound patterns (such as alliteration)
- ◆ Contrast
- ◆ Description and Imagery (i.e. using metaphor, simile and personification)
- ◆ The ‘rule of three’
- ◆ Repetition
- ◆ Hyperbole (using exaggeration for effect)
- ◆ Anecdotes

To help persuade: use key scientific facts and tell people about key events in the history of the Thames related to sewage, which can form part of your description and imagery, hyperbole and anecdotes and be done using emotive language, contrast and parallel structure.



## LESSON 2

# IF I LIVE HERE, WILL YOU LIVE HERE TOO?



### THE BIG IDEA

Interdependence and competition



### LESSON OUTCOMES

Could describe parasitic and symbiotic relationships.

Should describe the changes in predator and prey populations over time

Must know that all living organisms rely on plants or algae (as producers) for life.

Must understand how food chains interlink to form a food web within an ecosystem and explain the effect of the addition or removal of a species.



### RESOURCES

**Resource 2.1:** Thames' food chains

**Resource 2.2:** Interdependence questions

**Resource 2.3:** Thames' species information

**Resource 2.4:** Whales and dolphins in the Thames

**Resource 2.5:** Predator-prey role play

**Resource 2.6:** Predator-prey graph

**Resource 2.7:** Predator-prey graph statements

**Resource 2.8:** Symbiosis/Parasitism examples

**Resource 2.9:** Table template

## LESSON 2

# IF I LIVE HERE, WILL YOU LIVE HERE TOO?



### RESOURCES CONTINUED

**Resource 2.10:** Pyramids of number and biomass models

**Resource 2.11:** Pyramids of number and biomass construction

### YOU WILL ALSO NEED

- ◆ String
- ◆ Mini-whiteboards (optional)

### MATHEMATICAL SKILLS

- ◆ Scales/pictograms (for pyramids of numbers/biomass)

### KEYWORDS

- ◆ Food chain
- ◆ Food web
- ◆ Trophic level
- ◆ Interdependence
- ◆ Competition
- ◆ Predator
- ◆ Prey
- ◆ Pyramid of numbers
- ◆ Pyramid of biomass
- ◆ Parasite
- ◆ Parasitic

## LESSON 2: IF I LIVE HERE, WILL YOU LIVE HERE TOO?

### SETTING THE SCENE



KINGFISHER EATING A TADPOLE  
Pierre Dalous © Wikimedia Commons

### ONE RIVER MANY INHABITANTS

The Thames is a lowland river and along with the habitat of the river water itself, has a number of types of habitat along its length:

- ◆ mud, sand and shingle;
- ◆ grassland, woodland and scrub;
- ◆ salt marshes;
- ◆ reed beds.

The waters of the Thames are currently considered clean. Over 125 different species of fish thrive in the Thames, 400 invertebrate species and an increasing number of birds, such as swans, ducks, kingfishers, herons, great crested grebe, coots, moorhens and cormorants. There are also a population of seals, and occasionally larger mammals like porpoises have been sighted. Most famous is the Thames whale, a bottlenose whale spotted in January 2006 who sadly died after becoming stranded.

Many of the plants found near the river in London are not native, but accidental imports from overseas. This is due to imports passing through the port of London in the past, such as timber and food. Many plants thrive in London because, like other large cities, it is warmer than the surrounding countryside.

## LESSON 2: IF I LIVE HERE, WILL YOU LIVE HERE TOO?

### ACTIVITIES

#### STARTER: WHO DO YOU NEED?

Ask students to discuss in pairs what organisms they need to rely on. Then gather ideas from the class, and use this to review primary knowledge of food chains (producer → primary consumer → secondary consumer → tertiary consumer). Ask students why there is not often a quaternary consumer, use this to clarify that energy is lost through the food chain to respiration, excretion, homeostasis etc. That is also part of the reason why a consumer eats more the higher up the food chain it is. Ask students what would happen if there were no plants or algae, to ensure they understand that photosynthesis is vital for life. Algae actually produce around 40% of the world's oxygen, so their presence in river ecosystems is very important.

#### Differentiation

If students cannot recall primary knowledge, spend some time going through a food chain giving some examples.

#### MAIN 1: MAKING A WEB

Give students a number of food chains, Resource 2.1 (pages 30 – 32), from which they need to construct a food web of the Thames. This can be done either on paper, or by getting students to role-play where each is a particular organism and then they link to one another using string. Then ask students what happens when a particular organism is removed from the food web, to get them to articulate ideas about interdependence. After discussion they can write down what happens, using some examples or alternatively they can be asked to write answers to a set of differentiated questions, Resource 2.2 (page 33), to assess their understanding.

#### Differentiation

To extend students, instead of the food chains, provide them with a list of what each organism feeds on, Resource 2.3 (page 34), and get them to use that to construct a food web. To extend students get them to think about the addition of an organism, such as a whale or dolphin to the Thames' ecosystem, Resource 2.4 (page 35).

## MAIN 2: PREDATOR – PREY RELATIONSHIPS

Spilt the class into predators (e.g. heron) and prey (e.g. trout), a ratio of 3:1 or 4:1 (prey:predator) works well. Get half the class to sit out at the start. Talk them through what happens over time using Resource 2.5 (page 36) and get students to join and leave as appropriate to role play the changing dynamic. Then get students to try and sketch a graph of populations' numbers over time for both the predator and the prey (this could be done on a mini-whiteboard). Use this to discuss the class' ideas before showing them the correct graph using Resource 2.6 (page 37), which they then copy and annotate.

### Differentiation

To support students, provide them with the annotations which they then need to link to the correct part of the graph, Resource 2.7 (page 38). To extend students get them to write a paragraph to describe what is happening, in addition to an annotated graph.

## MAIN 3: CLOSE RELATIONSHIPS

Students are asked what they understand by symbiotic and parasitic relationships between organisms. Elucidate that there is a host, and in a parasitic relationship the parasite is negative for the host. A symbiotic relationship is where two organisms are interdependent; in most cases (but not all) there is mutually beneficial relationship.

Students are given an example of each within the Thames, Resource 2.8 (page 39):

- ◆ Symbiotic relationships – Angler fish (host) and bioluminescent bacteria.
- ◆ Parasitic relationships – 3-spine stickleback (host) and tapeworm *Schistocephalus solidus*. (It should be noted that often parasites try to keep their host alive, unlike in this particular relationship, but it is an interesting one to think of as a cycle, and is relevant to the context of the Thames).

Using this they draw up a table to summarise the relationships.

### Differentiation

To support students a template for the table can be used, Resource 2.9 (page 41).

To extend students you can discuss how parasites provide an opportunity for the transfer of genetic material between species. This can infrequently but dramatically result in evolutionary changes that would not otherwise occur, or that would otherwise take even longer.

## PLENARY

Model how to construct a pyramid of numbers and a pyramid of biomass, Resource 2.10 (page 42). Using information given, Resource 2.11 (page 44), students are tasked to construct pyramids of number and biomass.

### Differentiation

To support students, use interlocking cubes (often the maths department will have these) to model pyramids of number/biomass and get students to construct them from cubes before trying to draw them.

To extend students, ask them to construct pyramids of number that they expect from the food chains they looked at earlier in the lesson which are not in, Resource 2.11 (page 44), so they need to think about what likely numbers are.

### Homework idea

Students pick a particular organism in the River Thames to research to create a fact file, which includes what they eat, who they are eaten by and their competition. Students could be given one to investigate and then they could all be collated online as a 'Facebook' of the River Thames.

## Assessment questions

Adapt or extend questions based on activities, and/or use the following examples:

1. What happens if a species is added to the River Thames?  
**Extension:** How might new species arrive in the river?
2. What happens if a species is eliminated from the River Thames?  
**Extension:** How might species become eliminated from the river?
3. Why do predator and prey population sizes go up and down in cycles? **Extension:** How could this be affected by the introduction or removal of other species?
4. What is the difference between a parasitic and a symbiotic relationship?

## Further Reading

Thames Barrier resource pack:

**[bit.ly/1HQcP6I](https://bit.ly/1HQcP6I)**

Please refer to the terms and conditions for use of the Thames Barrier resource pack:

**[bit.ly/1Hecpn9](https://bit.ly/1Hecpn9)**

Information on some of Thames' fish from [thames-explorer.org.uk](http://thames-explorer.org.uk):

**[bit.ly/1C2yeJi](https://bit.ly/1C2yeJi)**

Information on some of Thames' birds from [thames-explorer.org.uk](http://thames-explorer.org.uk):

**[bit.ly/1FV55L4](https://bit.ly/1FV55L4)**

Information on the Thames whale at [thameswhale.info](http://thameswhale.info):

**[bit.ly/1CN8JXt](https://bit.ly/1CN8JXt)**

Article from The Guardian about porpoises spotted in the Thames:

**[bit.ly/1ArzeV](https://bit.ly/1ArzeV)**

## LESSON 2: IF I LIVE HERE, WILL YOU LIVE HERE TOO?

### RESOURCE 2.1: THAMES' FOOD CHAIN



Grass	→	Swan						
Algae	→	Swan						
Algae	→	River limpet	→	Trout	→	Heron		
Algae	→	River limpet	→	Trout	→	Kingfisher		
Algae	→	Freshwater shrimp	→	Leech	→	Trout	→	Heron
Algae	→	Freshwater shrimp	→	Leech	→	Trout	→	Kingfisher
Algae	→	Freshwater shrimp	→	Dragonfly	→	Frog	→	Swan
Algae	→	Blackfly	→	Dragonfly	→	Frog	→	Swan
Algae	→	Mayfly	→	Trout	→	Heron	→	Heron
Algae	→	Mayfly	→	Trout	→	Kingfisher	→	Kingfisher
Algae	→	Mayfly	→	Carnivorous Caddis	→	Trout	→	Heron
Algae	→	Mayfly	→	Carnivorous Caddis	→	Trout	→	Kingfisher
Algae	→	Mayfly	→	Dragonfly	→	Trout	→	Heron
Algae	→	Mayfly	→	Dragonfly	→	Trout	→	Kingfisher
Algae	→	Mayfly	→	Dragonfly	→	Frog	→	Swan

Help with keywords:

- ◆ Detritus is the remains of dead plants and animals.
- ◆ Phytoplankton are microscopic plants that live in water.
- ◆ Zooplankton are microscopic animals that live in water.



## LESSON 2: IF I LIVE HERE, WILL YOU LIVE HERE TOO?

### RESOURCE 2.1: THAMES' FOOD CHAIN



Algae	→	Mayfly	→	Dragonfly	→	Trout	→	Heron
Algae	→	Mayfly	→	Dragonfly	→	Trout	→	Kingfisher
Algae	→	Mayfly	→	Dragonfly	→	Frog	→	Swan
Algae	→	Mayfly	→	Carnivorous Stonefly	→	Trout	→	Heron
Algae	→	Mayfly	→	Carnivorous Stonefly	→	Trout	→	Kingfisher
Detritus	→	Worm	→	Frog	→	Swan	→	
Detritus	→	Worm	→	Dragonfly	→	Trout	→	Heron
Detritus	→	Worm	→	Dragonfly	→	Trout	→	Kingfisher
Detritus	→	Worm	→	Carnivorous Caddis	→	Trout	→	Heron
Detritus	→	Worm	→	Carnivorous Caddis	→	Trout	→	Kingfisher
Detritus	→	Freshwater shrimp	→	Leech	→	Trout	→	Heron
Detritus	→	Freshwater shrimp	→	Leech	→	Trout	→	Kingfisher
Detritus	→	Freshwater shrimp	→	Dragonfly	→	Trout	→	Heron
Detritus	→	Freshwater shrimp	→	Dragonfly	→	Trout	→	Kingfisher
Detritus	→	Freshwater shrimp	→	Dragonfly	→	Frog	→	Swan

Help with keywords:

- ◆ Detritus is the remains of dead plants and animals.
- ◆ Phytoplankton are microscopic plants that live in water.
- ◆ Zooplankton are microscopic animals that live in water.

## LESSON 2: IF I LIVE HERE, WILL YOU LIVE HERE TOO?

### RESOURCE 2.1: THAMES' FOOD CHAIN



Detritus	→	Blackfly	→	Leech	→	Trout	→	Heron
Detritus	→	Blackfly	→	Leech	→	Trout	→	Kingfisher
Detritus	→	Blackfly	→	Carnivorous Caddis	→	Trout	→	Heron
Detritus	→	Blackfly	→	Carnivorous Caddis	→	Trout	→	Kingfisher
Detritus	→	Blackfly	→	Dragonfly	→	Trout	→	Heron
Detritus	→	Blackfly	→	Dragonfly	→	Trout	→	Kingfisher
Detritus	→	Blackfly	→	Carnivorous Stonefly	→	Trout	→	Heron
Detritus	→	Blackfly	→	Carnivorous Stonefly	→	Trout	→	Kingfisher
Phytoplankton	→	River limpet	→	Trout	→	Heron		
Phytoplankton	→	River limpet	→	Trout	→	Kingfisher		
Phytoplankton	→	Zooplankton	→	Minnow	→	Swan		
Phytoplankton	→	Zooplankton	→	Swan mussel	→	Seal		
Phytoplankton	→	Freshwater shrimp	→	Leech	→	Trout	→	Heron
Phytoplankton	→	Freshwater shrimp	→	Leech	→	Trout	→	Kingfisher
Phytoplankton	→	Minnow	→	Swan	→			

Help with keywords:

- ◆ Detritus is the remains of dead plants and animals.
- ◆ Phytoplankton are microscopic plants that live in water.
- ◆ Zooplankton are microscopic animals that live in water.

## LESSON 2: IF I LIVE HERE, WILL YOU LIVE HERE TOO?

### RESOURCE 2.2: INTERDEPENDENCE QUESTIONS



Hint: In your answers refer to population numbers/level of other species.

#### 1.

- ◆ What will happen if all the mayfly population are removed or killed off?
- ◆ What will happen if all the dragonfly population are removed or killed off?
- ◆ What will happen if the freshwater shrimp population dramatically increases?
- ◆ What will happen if the leech population dramatically increases?

#### 2.

- ◆ What will happen if humans fish trout from the River Thames until its numbers are incredibly low?
- ◆ What will happen if more swans are introduced in to the River Thames?

#### 3.

- ◆ What will happen if a toxin kills animals in the river?
- ◆ What will happen if mayfly and blackfly populations are diseased and killed off by an insecticide?

## LESSON 2: IF I LIVE HERE, WILL YOU LIVE HERE TOO?

### RESOURCE 2.3: THAMES' SPECIES INFORMATION



Use this information to construct a food web:

- ◆ Heron and kingfishers eat big fish like trout
- ◆ Harbour seals eat swan mussels, along with different types of fish
- ◆ Swans eat grasses, algae, frogs and small fish like minnows
- ◆ Minnows feed on microscopic organisms, i.e. plankton
- ◆ Trout feed on leeches, river limpets, carnivorous stonefly, carnivorous caddis and dragonfly
- ◆ Leech feed on freshwater shrimp and blackfly
- ◆ Carnivorous stonefly feed on blackflies and mayfly
- ◆ Carnivorous caddis feed on mayfly, blackfly and worms
- ◆ Dragonfly feed on worms, blackfly and freshwater shrimp
- ◆ Frogs feed on worms and dragonfly
- ◆ Swan mussels feed on zooplankton
- ◆ Freshwater shrimp feed on detritus, phytoplankton and algae
- ◆ Blackfly feed on detritus
- ◆ Worms feed on detritus
- ◆ River Limpets feed on phytoplankton and algae
- ◆ Zooplankton feeds on phytoplankton
- ◆ Algae, grasses and phytoplankton photosynthesis and so obtain their energy from sunlight

## LESSON 2: IF I LIVE HERE, WILL YOU LIVE HERE TOO?

## RESOURCE 2.4: WHALES AND DOLPHINS IN THE THAMES



In December 2013 a pod of five porpoises were sighted in the Thames, and in January 2006 a bottlenose whale was sighted. The bottlenose whale ended up stranded, and sadly despite a rescue attempt to return it to the sea, it died. Its skeleton is in the National Research Collection at the Natural History Museum.

Bottlenose whales feed on shrimp, squid and many types of fish. Porpoises eat fish too. Porpoises require a high level of energy to sustain themselves, and need to eat around 10% of their bodyweight daily. A porpoise is usually between 45kg to 90kg, though some have been known to reach 180kg.

**Question:** What impact would a bottlenose whale or a pod of porpoises living in the Thames have on the Thames' ecosystem?



THE THAMES WHALE JUST AS RESCUERS BEGIN TO TRY TO SAVE HIM, 22 JANUARY 2006

© John Hyde, Wikimedia Commons

## LESSON 2: IF I LIVE HERE, WILL YOU LIVE HERE TOO?

## RESOURCE 2.5: PREDATOR-PREY ROLE PLAY



Spilt the class in to predators (e.g. heron) and prey (e.g. trout), a ratio of 3:1 or 4:1 (prey:predator) works well. Get half the class to sit out at the start. Talk them through what happens over time (using the script opposite) and get students to join and leave as appropriate to role play the changing dynamic.

**Script for predator-prey numbers cycle**

- ◆ There are some herons and a lot more trout. Herons need to eat many trout over a week to stay alive, so their numbers are not greater than the number of trout.
- ◆ As the herons feed on the trout, their numbers decrease.
- ◆ Now that there are less trout, less heron survive due to lack of food and their numbers decrease.
- ◆ Now that there are less heron, more trout survive and their numbers increase.
- ◆ Now that there are more trout, the herons have more food and their numbers increase.
- ◆ As the numbers of heron increase, more trout are eaten and their numbers decrease.
- ◆ Now that there are less trout, less heron survive and their numbers decrease.

Continue for a few cycles until students understand the dynamic.

(Heron and trout can be swapped with other predator-prey pairings such as swan and frog, or swan mussel and seal.)

## LESSON 2: IF I LIVE HERE, WILL YOU LIVE HERE TOO?

### RESOURCE 2.6: PREDATOR-PREY GRAPH



#### RELATIONSHIP BETWEEN PREDATOR AND PREY POPULATION NUMBERS

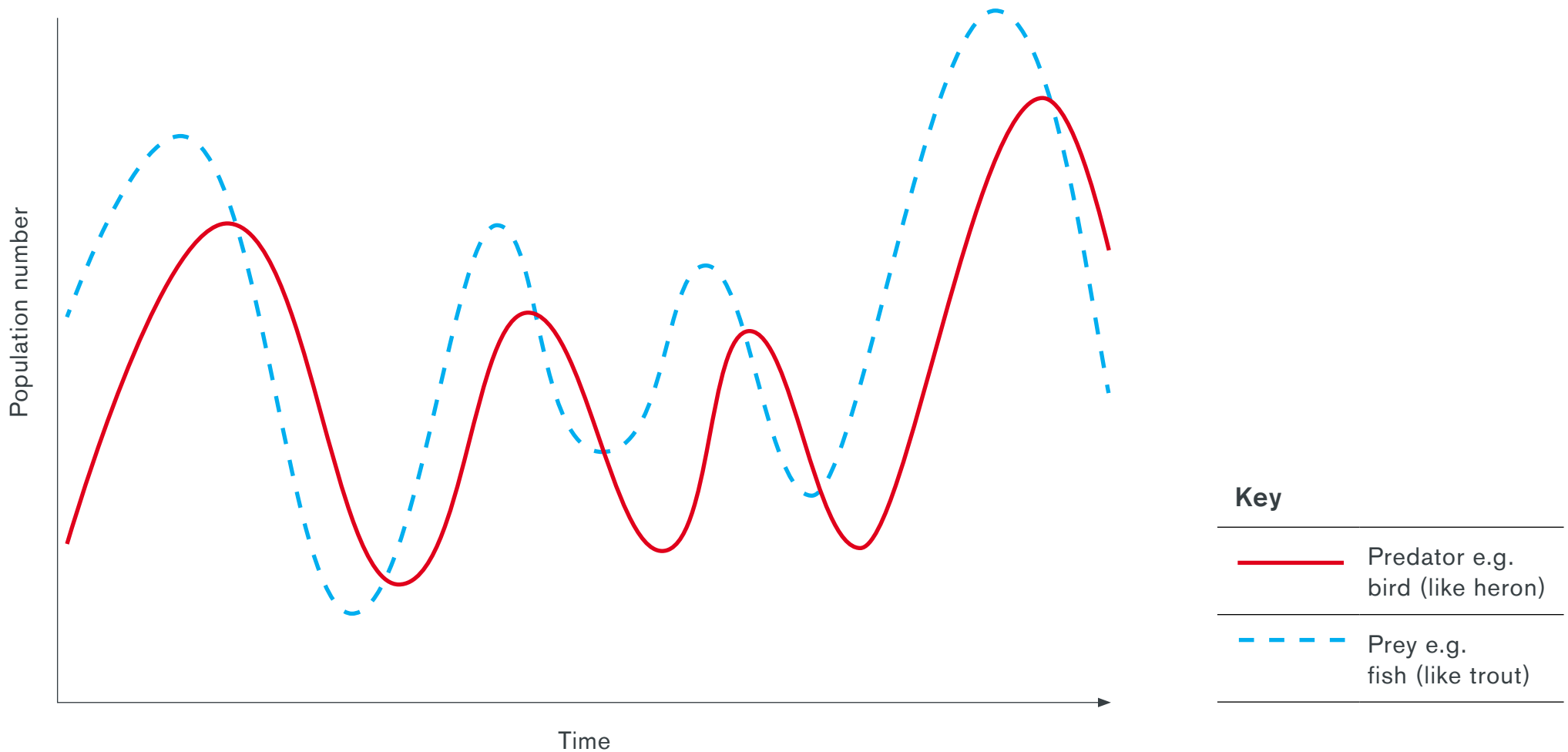

## LESSON 2: IF I LIVE HERE, WILL YOU LIVE HERE TOO?

### RESOURCE 2.7: PREDATOR-PREY GRAPH STATEMENTS



You can use these statements to annotate your graph:

(The key terms predator and prey can be swapped with specific examples, such as heron and trout.)

As the population of prey decreases, there is less food for the predators so their numbers fall.

As the population of prey increases, the number of predators increases because they have a greater food source.

Predators are at the top of the food chain, and so because of their energy needs there are less of them than there are of the prey.

As the population of predators increase, more prey are eaten and therefore their numbers fall.



## LESSON 2: IF I LIVE HERE, WILL YOU LIVE HERE TOO?

### RESOURCE 2.8: SYMBIOSIS/PARASITISM EXAMPLES



#### A symbiotic relationship in the Thames

Anglerfish is a large group of fishes that live in deep water. Generally they are found in the sea because of this, but there are some found in the Thames. Bioluminescent bacteria are bacteria that create luminescence (light) through a biological process, like firefly.

The relationship between the anglerfish and bioluminescent bacteria is mutualism, as both the host (the anglerfish) and the endosymbiont (the bacteria which live inside the fish) benefit from the relationship.

The anglerfish has a 'rod', which is an extension of the dorsal spine that goes above the mouth. This is home to a colony of bioluminescent bacteria. The light produced lures curious prey towards it. Meanwhile, the bacteria are provided nutrients and protection by the anglerfish.

Only female anglerfish have these rods and the bioluminescent bacteria, so it is also suggested that they may be used to attract a mate.

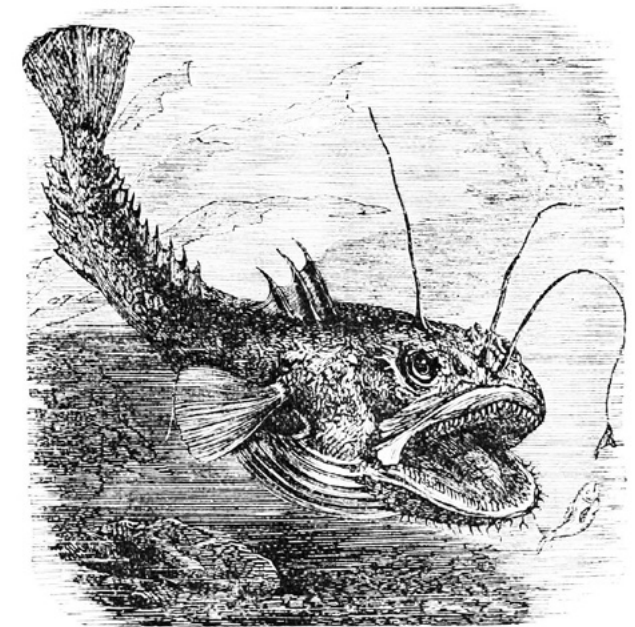

THE ANGLER FISH, 1879-80,  
Popular Science Monthly Volume 16  
© Wikimedia Commons

## LESSON 2: IF I LIVE HERE, WILL YOU LIVE HERE TOO?

### RESOURCE 2.8: SYMBIOSIS/PARASITISM EXAMPLES CONTINUED



Parasites benefit from their host, but their host does not benefit. Usually parasites don't result in the death of their host though, because they are relying on them to live. A common example is lice (fish get lice too). However the following example is an exception.

The 3-spine stickleback is a type of fish that is found in the Thames. The tapeworm they are host to, have two other hosts during its life cycle. Firstly, the larvae (which can swim) are eaten by small fresh water crustaceans. The stickleback fish eats these crustaceans. Inside the fish the larva grows in to a tapeworm. As the tapeworm grows it causes the fish's body to swell, which makes it more visible to predators like birds. It also appears to change its behavior – infected fish do not dart away when a predator approaches and often do not join shoals (groups of fish, in which there is protection from being in the group) and is therefore more likely to be eaten by a predator, such as a bird. Inside the bird the tapeworm lays its eggs. The eggs are excreted by the bird in to the river.

In the water they hatch into larvae, and the cycle begins again. In this case, the tapeworm wants its second host, the stickleback, to be eaten (and therefore die) in order for its own life cycle to continue.

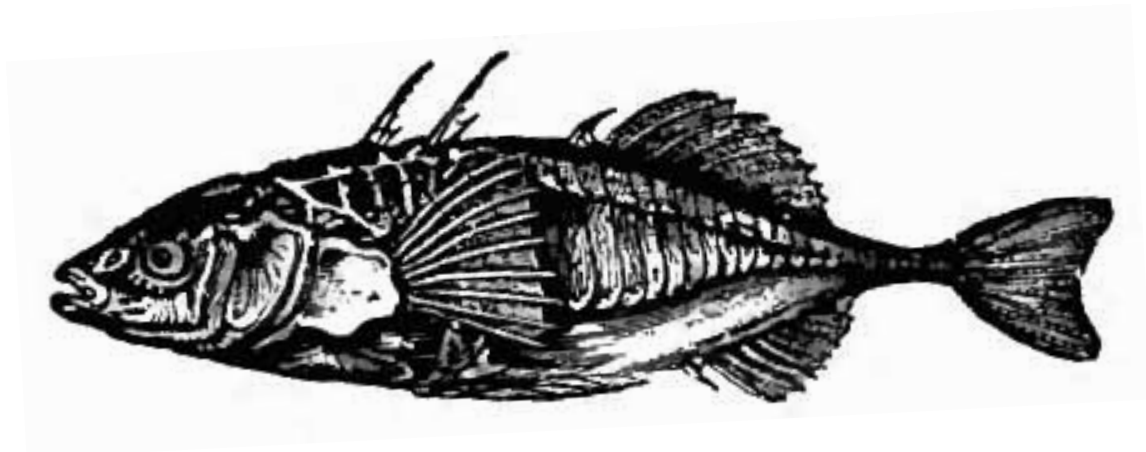

DRAWING OF GASTROSTEUS ACULEATUS, VAR. NOVEBORACENSIS, THREE-SPINED STICKLEBACK, 1911  
Encyclopaedia Britannica (11th ed.) Vol. 25  
© Wikimedia Commons

LESSON 2: IF I LIVE HERE, WILL YOU LIVE HERE TOO?

RESOURCE 2.9: TABLE TEMPLATE



Sybiotic (sp) and parasitic relationships

SIMILARITIES	DIFFERENCES

## LESSON 2: IF I LIVE HERE, WILL YOU LIVE HERE TOO?

### RESOURCE 2.10: PYRAMIDS OF NUMBER AND BIOMASS MODELS

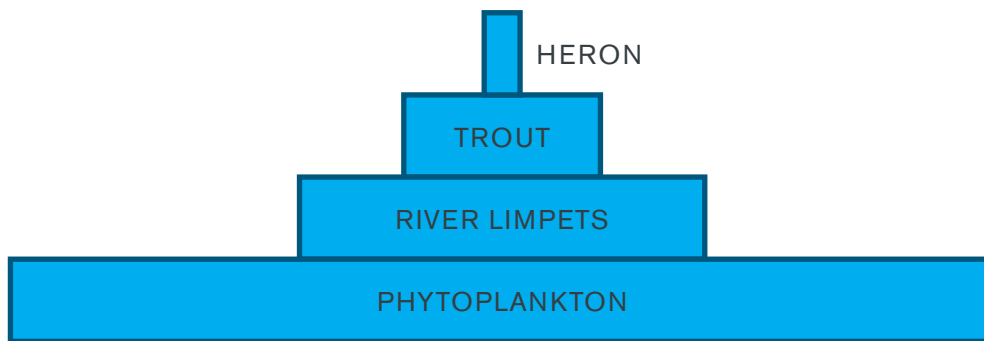

#### Pyramids of numbers

The population of each organism in a food chain can be shown in a graphical representation called a pyramid of numbers. The more organisms there are, the wider the bar (all bars are the same height). So you have to decide a scale, e.g. 0.2cm is equal to one. The producer in the food chain always goes at the bottom of the pyramid of numbers. The levels are called trophic levels.

Phytoplankton → River Limpet → Trout → Heron

As you go up the food chain, from one trophic level to another, energy is 'lost' at each stage to respiration, reproduction, movement, excretion and growth. This means organisms at each level have to eat more of the level before them. This usually means more in numbers and so you end up with a pyramid, as above.

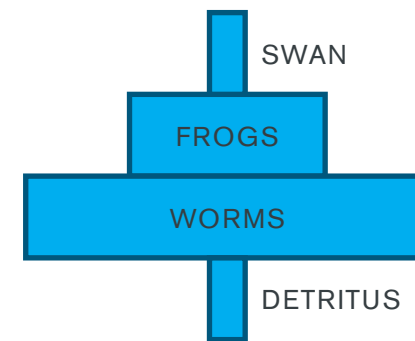

However, pyramids of numbers do not always look like a 'pyramid', because sometimes you have a large producer. For example, in the Thames a large animal may have died – perhaps even a seal. This become detritus, which is fed on by other organisms:

Detritus → Worm → Frog → Swan

## LESSON 2: IF I LIVE HERE, WILL YOU LIVE HERE TOO?

### RESOURCE 2.10: PYRAMIDS OF NUMBER AND BIOMASS MODELS CONTINUED

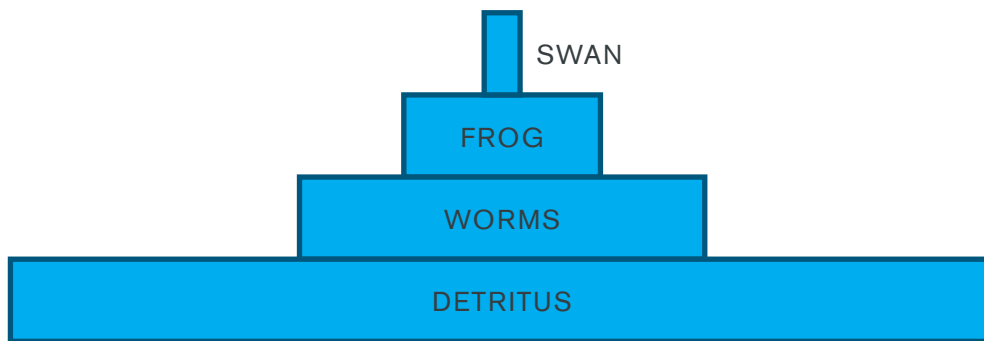

### Pyramids of biomass

However a large producer has a large mass. Biomass is the mass of an organism when dry (i.e. without water). In a pyramid of biomass, the width of the bar represents the mass of organisms. You still need to keep the bar heights the same and have a scale, for example 2cm width is 1kg.

## LESSON 2: IF I LIVE HERE, WILL YOU LIVE HERE TOO?

### RESOURCE 2.11: PYRAMIDS OF NUMBER AND BIOMASS CONSTRUCTION



Construct pyramids of number and biomass using the following data:

**Phytoplankton → Minnow → Swan**

---

Phytoplankton: 100,000, weighing 30kg

Minnow: 1000, weighing 16g

Swan: 1, weighing 10kg

**Algae → Mayfly → Carnivorous Stonefly → Trout → Kingfisher**

---

Algae: 1000, weighing 50kg

Mayfly: 10000, weighing 20kg

Carnivorous Stonefly: 500, weighing 15kg

Trout: 12, weighing 10kg

Kingfisher: 3, weighing 350g

## LESSON 3

### TAKING A CLOSER LOOK



#### THE BIG IDEA

Cell structure, including the use of microscopy and the differences between plant and animal cells



#### LESSON OBJECTIVES

Must use a microscope, label its parts, calculate the magnification and describe the differences between an animal and plant cell

Should explain some of the differences between plant and animal cells and make an accurate drawing from a microscope

Could describe the differences and similarities between an amoeba and other animal cells



#### RESOURCES

**Resource 3.1:** How a microscope works

**Resource 3.2:** Magnification practice

**Resource 3.3:** Microscope drawings – success criteria

**Resource 3.4:** List of suggested pre-prepared slides to use

**Resource 3.5:** Microscope to label

**Resource 3.6:** Microscope to label with keywords

**Resource 3.7:** How to prepare an Elodea slide

**Resource 3.8:** Amoeba information

## LESSON 3

### TAKING A CLOSER LOOK



#### YOU WILL ALSO NEED

- ◆ Microscopes (Ideally, including one USB microscope to visualise on screen)
- ◆ Elodea
- ◆ Tweezers
- ◆ Scalpel (to cut the Elodea in to more manageable pieces from which the students then tear off a leaf)
- ◆ Slides
- ◆ Coverslips
- ◆ Distilled water in dropper bottles
- ◆ Tissues
- ◆ Pre-prepared animal, algae and plant slides
- ◆ Pre-prepared amoeba slides

#### MATHEMATICAL SKILLS

- ◆ Scale drawings
- ◆ Multiplication

#### KEYWORDS

- ◆ Microscope
- ◆ Magnification
- ◆ Stage
- ◆ Slide
- ◆ Coverslip
- ◆ Coarse focus
- ◆ Fine focus
- ◆ Focusing knob
- ◆ Objective lens
- ◆ Eyepiece lens
- ◆ Arm
- ◆ Mirror



## LESSON 3: TAKING A CLOSER LOOK

### SETTING THE SCENE

Robert Hooke was an English scientist, born in 1635 on the Isle of Wight. He lived in London for a time and died in London in 1703. He was a polymath and did not limit himself to one area of scientific endeavor. He is known for Hooke's Law in physics but also for coining the term 'cell' used in biology. Using a microscope made in London, he examined the structure of a myriad of objects, including snowflakes, fleas, lice and plants. He coined the term "cell" from the Latin *cella*, which means "small room," because he compared the cells he saw in cork to the small rooms that monks lived in. In 1665 Hooke published *Micrographia*, a book describing observations made with microscopes. The leather and gold-tooled microscope he used to make the observations for *Micrographia* is on display at the National Museum of Health and Medicine in Washington, DC in the USA.

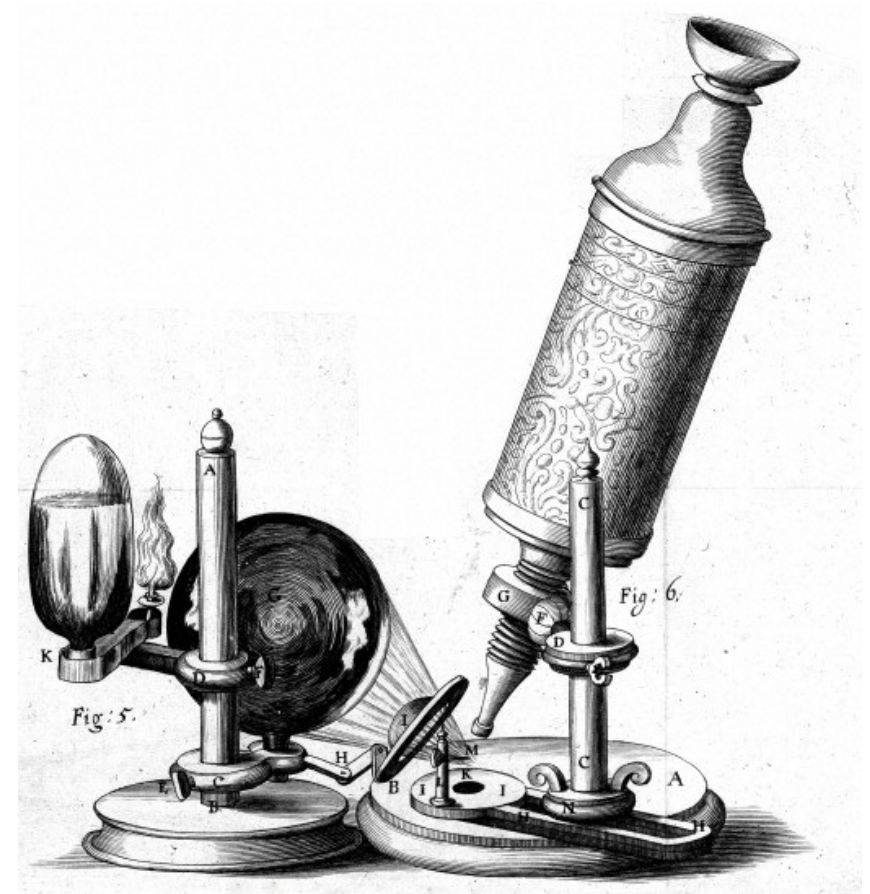

MICROGRAPHIA DETAIL: MICROSCOPE, 1665,  
Robert Hooke © Wellcome Library, London

## LESSON 3: TAKING A CLOSER LOOK

### ACTIVITIES

#### STARTER: ZOOMING IN

Show a high-resolution image of a scene (like a landscape) on the interactive white board, and demonstrate the effect of 'zooming in'. Ask students why we use microscopes and ensure they are clear it is because what we are looking at is too small to be seen by the naked eye.

Explain how a microscope magnifies an image, Resource 3.1 (page 51), can be used, along with a microscope to demonstrate the parts being referred to. Students will need to copy down the equation to calculate the magnification. Students can be given a series of total magnifications to calculate, Resource 3.2 (page 52).

#### Differentiation

Students can be extended by not allowing them to use a calculator.

#### MAIN 1: WHAT'S IN A DRAWING?

Explain that drawing using a microscope is a way of scientists recording observations and therefore the drawings are a piece of scientific evidence. Ask them to come up with success criteria for these drawings, or you can use Resource 3.3 (page 53). The criteria should include: drawn in pencil, note of magnification used, has a title, includes labeling and drawn neatly.

Demonstrate how to use a microscope, going through the parts of a microscope. Include information relating to safety, including how to carry a microscope and what to do with any broken glass. (If you are unsure consult the CLEAPSS guide which will be available to you via school if the school has a CLEAPSS membership.) Then, if you have a USB microscope which can be visualized on the interactive white board or other screen, you can use one of the pre-prepared slides to demonstrate how to focus and point out what can be seen.

Students then label a microscope, Resource 3.5 (page 56), once this is checked they can go on to view one (or more) of the pre-prepared animal specimen; see Resource 3.4 (pages 54 – 55) for ideas, and draw what they see, following the agreed success criteria.

#### Differentiation

To support students they can be provided with the keywords for labelling the microscope, Resource 3.6 (page 57).

To extend students, they can also look at pre-prepared algae specimens.

## MAIN 2: PREPARING A SLIDE

Students prepare a plant cell slide, using a waterweed like Elodea, Resource 3.7 (page 58). They then make a labelled drawing from what they see.

### Differentiation

To support students they can be shown the general structure of a plant cell on the interactive white board, so they know what to look for.

Students can be extended by looking at amoeba, which is neither a plant nor an animal but a protozoa. Pre-prepared slides can be bought, Resource 3.4 (page 54 – 55).

## PLENARY

Using their diagrams, students come up with a table of similarities and differences between plant and animal cells.

### Differentiation

Students can be prompted with questions, like ‘does it have a cell wall?’ to help them complete their table, or provided with a textbook for support.

To extend students who looked at the amoeba, they can add a paragraph about how an amoeba differs and is similar to animal cells. See Resource 3.8 (page 59) for more information on amoeba.

Students can be extended by explaining the differences they have tabulated.

### Homework idea

Students research where they will be going for their Explore session, and note down 3 key facts to share with the class.

## Assessment questions

Adapt or extend questions based on activities, and/or use the following examples:

1. What is the purpose of a microscope?  
**Extension:** How does a microscope work?
2. Why do scientists use drawings to record observations, rather than just written descriptions?
3. What are the key differences between an animal and a plant cell?  
**Extension:** Why does an animal cell not have a cell wall?

### Sources and further information on Robert Hooke:

history-of-the-microscope.org:

**[bit.ly/1tsyRVW](https://bit.ly/1tsyRVW)**

britannica.com:

**[bit.ly/1HysGqr](https://bit.ly/1HysGqr)**

bbc.co.uk/history:

**[bbc.in/1GR9MXf](https://bbc.in/1GR9MXf)**

## LESSON 3: TAKING A CLOSER LOOK

## RESOURCE 3.1: HOW A MICROSCOPE WORKS



Microscopes allow us to see small objects, using lenses. The simplest microscope of all is a magnifying glass made from a single convex lens, which typically magnifies by about 5–10 times. Microscopes used in school are compound microscopes with two lenses: one above the object (called the objective lens) and another lens near your eye (called the eyepiece lens). Most compound microscopes in schools can magnify by 10, 20, 40, or 100 times, though professional ones can magnify by 1000 times or more.

**How does it work?**

1. Daylight from the room (or from a bright lamp) shines in at the bottom.
2. The light rays hit an angled mirror and change direction, travelling straight up toward the specimen. The mirror can be adjusted to capture more light and change the brightness of the image you see.
3. The light rays pass through a hole in an adjustable horizontal platform called the stage.
4. The stage moves up and down when you turn a knob (coarse focus) on the side of the microscope. By raising and lowering the stage, you move the lenses closer to or further away from the object you're examining, adjusting the focus of the image you see. There is also a fine focus knob, which lets you focus clearly on the image.
5. You prepare a specimen of what the object you want to look at. The specimen has to be a very thin slice so light rays will pass through.
6. You mount the specimen on a glass slide with a glass cover slip on top to keep it in place.
7. Light traveling up from the mirror passes through the glass slide, specimen, and cover slip to the objective lens. It works by spreading out light rays from the specimen so they appear to come from a bigger object.
8. The eyepiece lens magnifies the image from the objective lens, rather like a magnifying glass. You look down the eyepiece to see a magnified image of the object. The total magnification is the sum of the objective lens and eyepiece lens magnification.

$$\frac{\text{Magnification of eyepiece lens}}{\text{Magnification of objective lens}} \times \text{Magnification of objective lens} = \text{Magnification of object}$$

## LESSON 3: TAKING A CLOSER LOOK

### RESOURCE 3.2: MAGNIFICATION PRACTICE



What is the total magnification when the eyepiece magnification is x10, and the objective magnification are:

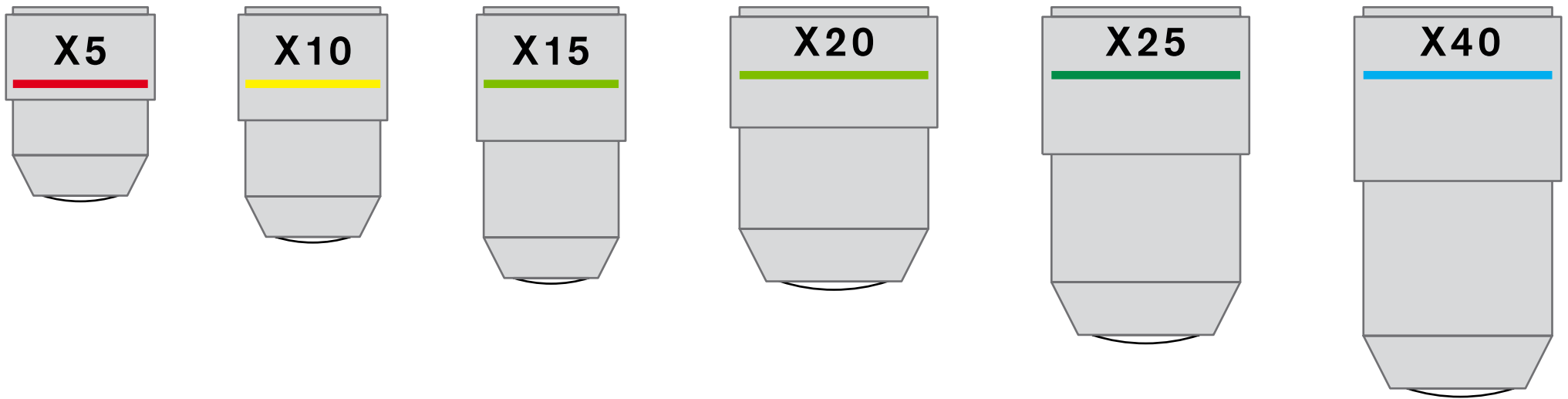

Magnification of eyepiece lens  $\times$  Magnification of objective lens

= Magnification of object

## LESSON 3: TAKING A CLOSER LOOK

### RESOURCE 3.3: MICROSCOPE DRAWINGS – SUCCESS CRITERIA



#### Your microscope drawing must:

- ◆ Be drawn using pencil
- ◆ Be drawn neatly
- ◆ Have a title
- ◆ Have labels of all the features you can identify
- ◆ Have information on the magnification you were looking at

#### Your microscope drawing could:

- ◆ Have information about the colours or textures you see

## LESSON 3: TAKING A CLOSER LOOK

## RESOURCE 3.4: LIST OF SUGGESTED PRE-PREPARED SLIDES TO USE



Pre-prepared slides can be bought from your usual technical suppliers, such as Phillip Harris and Timstar. The list below provides an extensive selection of possible species and sections of species for which slides are known to have been made, which can be used as a starting point to source relevant slides:

**Cyclops sp.** (*Freshwater Copepoda*)

- female

**Cypris sp.** (*Freshwater Ostracoda*)**Daphnia sp.**

- Water Fly (*Cladocera*)

**Diaptomus sp.** (*Freshwater Copepoda*)

- female

**Gammarus sp**

- Shrimp (*Ampipoda*)

**Diving Beetle** (*Coleoptera*)

- larva

**Dragonfly** (*Odonata, Anisoptera*)

- nymph

**Water Beetle** (*Coleoptera*)

- larva
- spiracle
- tracheal tubes of larva

**Water Springtail** (*Collembola*) **Podura sp.****Scyliorhinus canicular**

- Dogfish
  - semi-circular canal
  - jaw v.s.
  - gill t.s.
  - placoid scales
  - branchial region t.s.

**Trout t.s.**

- 6 weeks
- ear region
- liver region
- tail region
- eye region

**Caddishfly**

- Hydropsyche
  - larva
- Rhyacophila
  - larva

**Rana sp.**

- ovuum
  - early segmentation
- tadpole
  - newly hatched
    - visceral pouches

**Rana temporaria**

- brain v.l.s
- heart l.s
- heart t.s.
- later embryo v.s.
- ova
  - gastrula
- tadpole
  - external gills
  - internal gills



## LESSON 3: TAKING A CLOSER LOOK

### RESOURCE 3.4: LIST OF SUGGESTED PRE-PREPARED SLIDES TO USE CONTINUED



**Aphanothece sp.**

– fluid mount

**Asterionella sp.**

– fluid mount

**Batrachospermum sp.**

– fluid mount

**Chaetophora sp.**

**Chlamydomonas sp.**

– fluid mount

**Cladophora sp.**

– fluid mount

**Closterium sp.**

– fluid mount

**Cosmarium sp.**

– fluid mount

**Desmidium sp.**

– fluid mount

**Diatoma sp.**

– fluid mount

**Diatoms**

– mixture freshwater

**Euastrum sp.**

– fluid mount

**Euglena sp.**

– fluid mount

**Fragilaria sp.**

– fluid mount

**Microasterias sp.**

– fluid mount

**Microspora sp.c**

**Mougeotia sp.**

– fluid mount

**Navicula sp.**

– fluid mount

**Netrium sp.**

– fluid mount

**Odeogonium sp.**

– fluid mount

**Oscillatoria sp.**

– fluid mount

**Spirogyra sp.**

– vegetative  
– fluid mount

**Stigeoclonium sp.**

– fluid mount

**Synedra sp.**

– fluid mount

**Tabellaria sp.**

– fluid mount

**Tetraspora sp.**

**Ulotrihix sp.**

– fluid mount

**Vaucheria sp.**

– fluid mount

**Volvox sp.**

– entire

**Volvox sp.**

– fluid mount

**Zygnema sp.**

– fluid mount

**Lily**

– stem t.s.

**Onion**

– epidermis

**Orchid**

– arial root

LESSON 3: TAKING A CLOSER LOOK

RESOURCE 3.5: MICROSCOPE TO LABEL

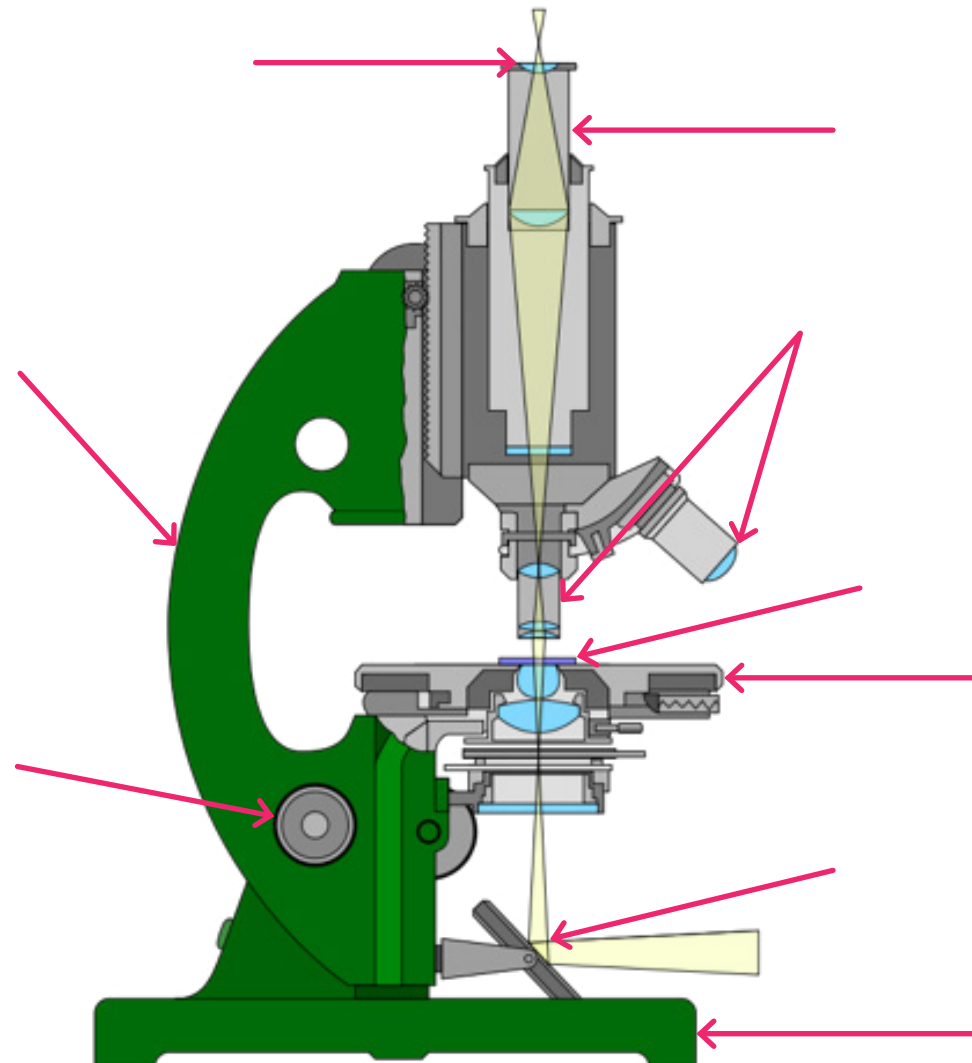

USING WITH MODIFICATION: MICROSCOPE  
WITH LABELS, 12 JANUARY 2008,  
Tomia Gfdl © Wikimedia Commons

## LESSON 3: TAKING A CLOSER LOOK

### RESOURCE 3.6: MICROSCOPE TO LABEL WITH KEYWORDS



- ◆ Base
- ◆ Arm
- ◆ Focusing knob
- ◆ Eyepiece lens
- ◆ Eyepiece
- ◆ Specimen on slide
- ◆ Stage
- ◆ Objective lenses
- ◆ Mirror

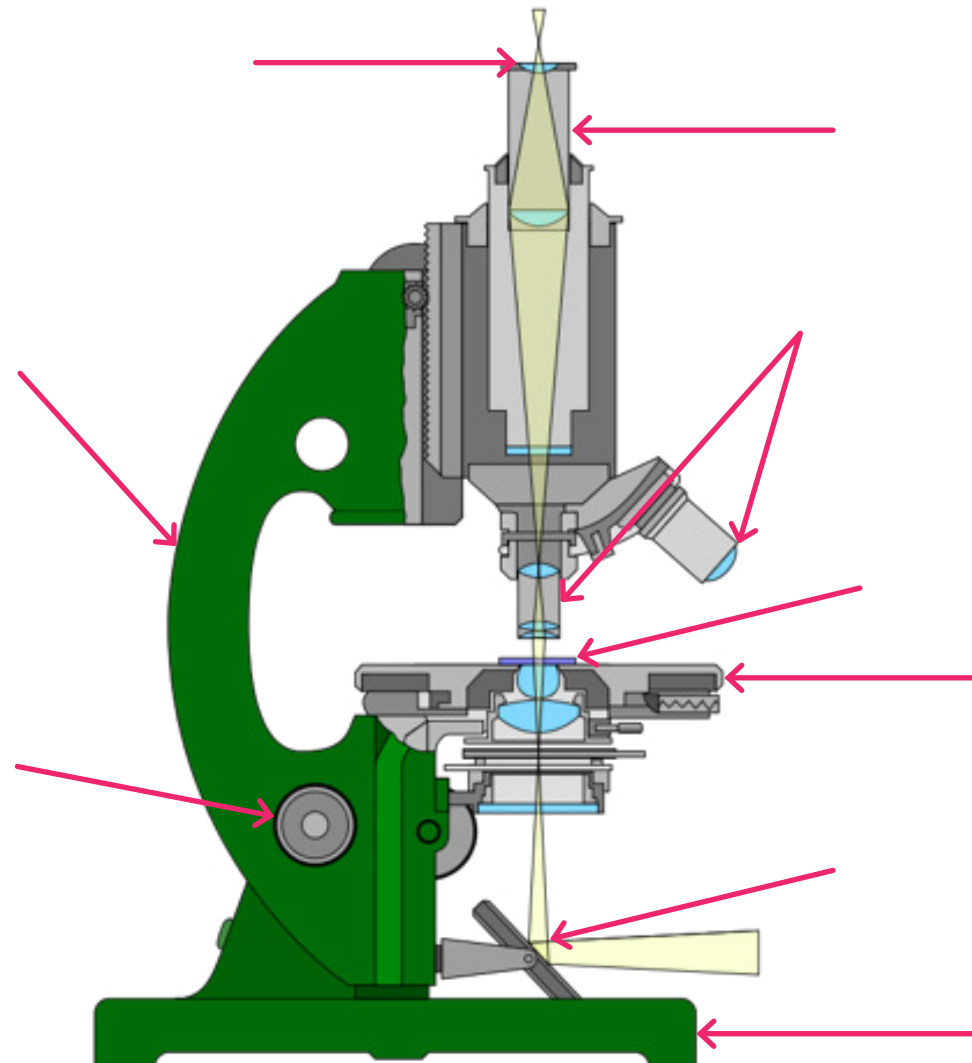

USING WITH MODIFICATION: MICROSCOPE  
WITH LABELS, 12 JANUARY 2008,  
Tomia Gfdl © Wikimedia Commons

## LESSON 3: TAKING A CLOSER LOOK

### RESOURCE 3.7: HOW TO PREPARE AN ELODEA SLIDE



1. Tear off one small leaf from the Elodea plant. Use tweezers to place it on a clean slide. Your fingers must not touch the slide or you will leave fingerprints that will disrupt the image under the microscope.
2. Add one drop of distilled water to the slide.
3. Stand a thin glass cover slip on its edge near the leaf, next to the drop of water.
4. Slowly lower the other side of the cover slip until it covers the leaf completely. Make sure there are no air bubbles.
5. Make sure the lowest power lens (the shortest lens) is in place over the stage. Place the slide onto the stage of the microscope.
6. Look through the eyepiece and turn the coarse focus knob (the largest knob) until an image comes into focus.
7. Looking from the side of the microscope, rotate to the next power lens.
8. Use the fine focus knob (the smallest knob) to make the image as focused as possible. You should see a row of cells, like bricks.
9. Again, looking from the side of the microscope, rotate the lenses to the next lens. You may be able to see lots of small green dots in each cell. If you need to, use the fine focus knob (the smallest knob) to get the image into focus.
10. Switch to the lowest power lens and then remove the slide.

You can draw a picture of what you see with any of the objective lens. If you only have time to do one drawing, choose the highest power lens to do that. If you have time, make a drawing with a lower power lens image as well.

## LESSON 3: TAKING A CLOSER LOOK

## RESOURCE 3.8: AMOEBIA INFORMATION



An amoeba is one of a group of species which are all single-celled protozoa in the phylum Sarcodina, and make up part of the animal kingdom. The word amoeba comes from a Greek word meaning “to change.” The amoeba moves by constantly changing its body shape, forming extensions termed pseudopods into which the rest of it flows.

Amoebas live in freshwater, salt water and soil, as well as surviving as parasites in moist body parts of animals. They are composed of cytoplasm which is divided in to two parts: an inner grainy mass (endoplasm) containing structures called organelles including at least one nucleus (some species have more than one); and a thin, clear, gel-like outer layer that acts as a membrane (ectoplasm) which allows food, water, carbon dioxide and oxygen to pass in and out. Water from the surrounding environment flows through the amoeba’s ectoplasm by osmosis. When too much water accumulates in the cell, the excess is enclosed in a contractile vacuole and squirted back out.

Amoeba eat bacteria, algae and other protozoa. The pseudopods are used to surround and capture food. An opening in the membrane allows the food particles and water to enter the cell. On entering they are enclosed to form food vacuoles. Within the vacuoles, food is digested by enzymes before being absorbed. The food vacuole then disappears and liquid waste is excreted through the membrane.

Some amoebas protect their bodies by covering themselves with sand grains. Others secrete a hardened shell that forms around them but leave an opening through which they extend their pseudopods. When water or food is scarce, some amoebas secrete a protective body covering called a cyst membrane. They exist in a cyst form until conditions are more favorable for survival outside.

The amoeba usually reproduces asexually by fission: the cytoplasm pinches in half and pulls apart to form two identical amoeba (daughter cells). The hereditary material (DNA) is identical in the two daughter cells, as it was duplicated before division.

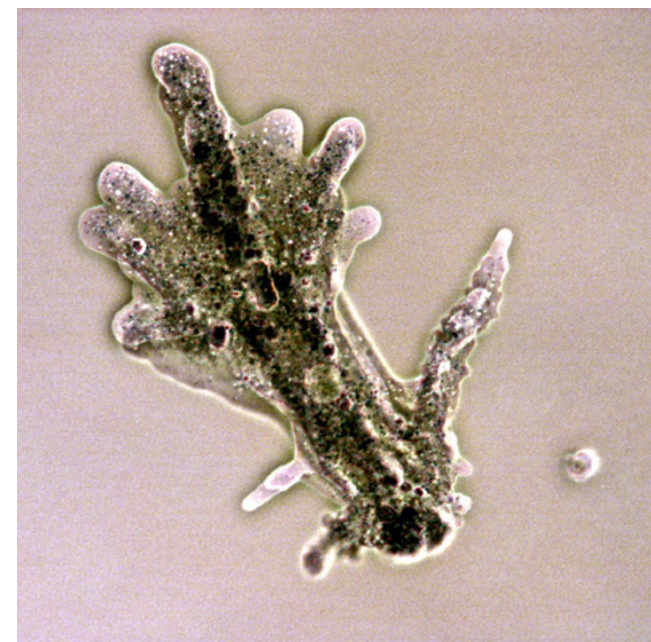

AMOEBIA PROTEUS, 6TH DECEMBER 2011

© Wikimedia Commons

Visible are the contractile vacuole (circular) and the nucleus (somewhat dumbbell-shaped).

# EXPLORE

Students visit a creek/river environmental site to investigate populations (or if this is not possible, then they can go pond dipping). This could be done as part of a day that involves visits for the design & technology and physics Thames' units.



## EXPLORE LONDON RIVER LIFE



### THE BIG IDEA

Ecosystems, surveying and sampling as investigative methods and poster presentations as a method of sharing scientific research.



### LEARNING OBJECTIVES

Could make links between different species found in their survey and how they are interdependent.

Should link the findings of a survey with characteristics of the water, such as pH and temperature.

Must carry out a survey of a water site (such as pond dipping) safely and accurately, using classification keys.



### RESOURCES

**Resource 4.1:** Success criteria for scientific poster

**Resource 4.2:** a, b and c scientific poster templates

## EXPLORE

### LONDON RIVER LIFE



#### YOU WILL ALSO NEED

- ◆ Classification keys, appropriate to your site (these may be provided by your site)
  - ◆ Health and safety briefing, appropriate to your site (this may be provided by your site)
  - ◆ Sampling trays, fishing nets, magnifying glasses and pooters – required to carry out the survey (this may be provided by your site)
  - ◆ Clipboard, pencils and paper (for data collection)
  - ◆ Cameras (or students could use their own devices)
  - ◆ Large paper (A1 or larger) for the posters, or smaller pieces of paper could be written on by students and affixed to a larger piece of sugar paper
- ◆ (For follow up in school: Video creating and editing software)

#### MATHEMATICAL SKILLS

- ◆ Data handling and presentation



## EXPLORE: LONDON RIVER LIFE

### PRE-VISIT ORIENTATION

This is to be carried out in school, either before setting off or on an earlier day.

If it has been possible for students to do the homework from the last Discover session, ask them to share their facts about the site you will be visiting. If this has not been possible tell them a bit about the site. Ask students what species they think they may find, and/or which will be the species they think they will find most frequently. This can be used to set up a competition, where each student suggests a species and at the end of the visit, the student who chooses the one that was found most frequently wins. Alternatively, all the species could be collated to form a 'bingo' and students have to attempt to find all of them while on the visit.

Inform students that along with finding out what lives at the site, they will be investigating the characteristics of the water and its quality. Get students to contribute ideas about what they think they would need to measure and record about the water. Extend them by asking them why each of the things they mention is important to record.

## EXPLORE: LONDON RIVER LIFE

### SETTING THE SCENE

A scientific poster is a visual presentation of scientific research in a standard form, with heading, name of researcher, name of research institute, text, tables and illustrations displaying the results of the research. It is used at scientific conferences, in addition to lectures. A special session is usually set aside for the presentation of posters. The researchers can stand nearby to answer questions from other conference participants.

The scientific poster format is an excellent way of presenting students' research work. It necessitates setting out all the stages of the research in a condensed, clear and interesting form. The process requires thought and planning on selection of information and on design. Also when displaying their posters in a 'conference' style, students can answer and ask questions.

Depending on which site you visit, there may not be adequate facilities for the poster to be created and/or displayed, so you may wish to do the related activities back at school and focus the visit on data gathering.

If you are doing this visit as part of a visit combining the Design & Technology and Physics unit, it is also suggested that you do the poster creation and display back at school.

Posters can be kept and shown in an exhibition for other students, parents and visitors to see. The exhibition could be on display for an extended period, for the enjoyment of visitors and as a source of pride for the students.

More information can be found here:  
[bit.ly/1LFec57](https://bit.ly/1LFec57)



ENTRANCE TO WWT LONDON WETLAND CENTRE  
M J Richardson © Wikimedia Commons

## EXPLORE: LONDON RIVER LIFE

### ACTIVITIES

#### STARTER

As a warm up, get students to spin on the spot and then call out 'stop' at which point they freeze. From where they are, ask them what they see. Can they see something related to science from their spot? Can they see any plants? Can they see any animals? This can be repeated a few times.

Ensure students are fully briefed on health and safety. Explain how to carry out the survey (including demonstrating use of equipment such as a pooter or fishing net) and how to use classification keys (which should have been used in primary school). Assemble students in to small teams, ideally of three students.

#### MAIN 1: SURVEY

Students carry out a survey looking at the species they find and also measuring the water quality and characteristics including pH, temperature and opacity/colour. (The site you visit may provide worksheets to record information, alternatively you can get students to construct simple tables and tally charts.) Students use classification keys.

Get students to take photos of some of the things they find, and of the site in general, which they will use when they are back in school for their Connect session. They may also wish to take a short video or audio clips, for example of birdsong or of a moving animal.

#### MAIN 2: POSTER PRESENTATION

Students decide how to present their findings in a poster using appropriate methods of data handling. Provide students with success criteria and explain the use of posters by scientists, Resource 4.1 (page 67).

#### Differentiation

To support students, Resource 4.2; A, B or C (pages 68 – 70) can be used as a template for their poster.

To extend students ask them to explain their findings relating the characteristics of the water, Resource 4.2 B (page 69) with what they have found there and to describe how they think the organisms they found are related to one another, Resource 4.2 C (page 70).

## PLENARY: CONFERENCE

Students look at each other's posters and provide feedback relating back to the success criteria, Resource 4.1 (page 69). This could be done with students writing a 'what went well' and 'even better if' on a Post-it note as they rotate around the different posters. In addition, at all times one student from the group should stay with the poster, to answer questions from their peers. This can be rotated, so all students get a chance to be the 'researcher' who fields questions and also to view others' posters and ask their peers questions.

## Homework idea

Students have to come up with their own classification key for a group of organisms.

Students (in their groups) create a video (which could include just still photos and audio) describing their visit and what they found. The best video(s) could be shared in an assembly or on the school intranet/e-learning platform.

## Assessment questions

Adapt or extend questions based on activities, and/or use the following examples:

1. What were the three species you found more frequently? **Extend:** Why do you think those species are so frequent here?
2. What rating would you give the quality of the water here? **Extend:** Why would you give it that rating?
3. Why do you think scientists use posters as one way of sharing their research? **Extend:** What do you think the benefits and drawbacks are of sharing scientific research as a poster, compared to a talk and to a journal article

## Further reading

Many of the places listed to visit have their own education programme so you may wish to use their expertise and change the plan for the Explore from what is described here.

Learning skills for science is a set of comprehensive resources developed through research to support teachers to teach skills explicitly with content. There is a set of resources relating to making a scientific poster:

[bit.ly/1Kvcvww](https://bit.ly/1Kvcvww)

## EXPLORE: LONDON RIVER LIFE

### RESOURCE 4.1: SCIENTIFIC POSTER – SUCCESS CRITERIA



#### A science poster at a basic level will be:

- ◆ Clear and legible
- ◆ Have a clear title and sections
- ◆ Be designed to be read from left to right (like a newspaper)
- ◆ Include your names and the school name
- ◆ Involve input from everyone in the group
- ◆ Include information about your method and your results
- ◆ Describe some conclusions

#### A presentation at a competent level will be:

- ◆ Use colour to attract attention, but do not use colour in a way that distracts from the content
- ◆ Not overcrowded, so there is space around tables and text
- ◆ Justify and explain some conclusions

#### A science poster at a mastery level will be:

- ◆ Make links between different pieces of data, such as the pH and the population numbers of different species

EXPLORE: LONDON RIVER LIFE

RESOURCE 4.2: A – SCIENTIFIC POSTER TEMPLATE



<b>TITLE</b>		<b>Logo</b> You can include the school logo or a team logo here.
<b>Authors (the names of the people in your group)</b>		
<b>Location</b> State where you carried out your survey. You may include a sketch.	<b>Results</b> Split your results into sections.  This first section could include data about the environment, such as the pH and temperature of the water and observations of the colour.	<b>Results</b> You might want to focus on small invertebrates in one section, and then fish in another section.
<b>Method</b> Describe briefly what you did.  This could be in numbered steps, you also could include diagrams.	<b>Results</b> Try and show your results graphically where possible.  Think about which graph suits your data A pictogram? A pie chart? A Bar Chart?	<b>Conclusions</b> Using bullet points, describe what you concluded about the quality of the water.

EXPLORE: LONDON RIVER LIFE

RESOURCE 4.2: B – SCIENTIFIC POSTER TEMPLATE



<b>TITLE</b>		<b>Logo</b> You can include the school logo or a team logo here.
<b>Authors (the names of the people in your group)</b>		
<b>Location</b> State where you carried out your survey. You may include a sketch.	<b>Results</b> Split your results into sections. This first section could include data about the environment, such as the pH and temperature of the water and observations of the colour.	<b>Results</b> You might want to focus on small invertebrates in one section, and then fish in another section.
<b>Method</b> Describe briefly what you did. This could be in numbered steps, you also could include diagrams.	<b>Results</b> Try and show your results graphically where possible. Think about which graph suits your data. A pictogram? A pie chart? A Bar Chart?	<b>Conclusions</b> Using bullet points, describe what you concluded about the quality of the water. Link your data about the water (e.g. pH and temperature) with the species you found.

EXPLORE: LONDON RIVER LIFE

RESOURCE 4.2: C – SCIENTIFIC POSTER TEMPLATE



<b>TITLE</b>		<b>Logo</b> You can include the school logo or a team logo here.
<b>Authors (the names of the people in your group)</b>		
<b>Location</b> State where you carried out your survey. You may include a sketch.	<b>Results</b> Split your results into sections. One section could be measurements you took, then another one could share species data.	<b>Interdependence</b> How do you think the different species you found relate to one another? Did you find any predator-prey pairs?  Do the amounts of each species you found tell you anything?
<b>Method</b> Describe briefly what you did.  This could be in numbered steps, you also could include diagrams.	<b>Results</b> Try and show your results graphically where possible.  Think about which graph suits your data. A pictogram? A pie chart? A Bar Chart?	<b>Conclusions</b> Using bullet points, describe what you concluded about the quality of the water. Link your data about the water (e.g. pH and temperature) with the species you found.



## EXPLORE: LONDON RIVER LIFE

### POSSIBLE SITES

#### **Bow Creek Ecology Park**

##### **Bidder Street, E16 9ST**

There are surfaced paths around the site. There is no parking but the site can be reached via East India Dock or Canning Town stations.

[bit.ly/1FixMpH](https://bit.ly/1FixMpH)

#### **Deptford Creek**

##### **14 Creekside, SE8 4SA**

Offers a large fully equipped classroom, and along with access to the creek there is a freshwater pond. They have everything you need for both the survey and to measure features of the water. Teachers at the site can tailor sessions for your class.

[bit.ly/1G9gKGp](https://bit.ly/1G9gKGp)

#### **Greenwich Peninsula Ecology Park**

##### **John Harrison Way, SE10 0QZ**

The site has lakes within an ecology part that is adjacent to the Thames, and includes shallow pools suitable for survey work.

[bit.ly/1Nziq1j](https://bit.ly/1Nziq1j)

## EXPLORE: LONDON RIVER LIFE

### POSSIBLE SITES CONTINUED

Some non-Thames alternatives if none of the above are possible:

#### Hampstead Heath Ponds

In North West London, this site has a number of ponds that are accessible. Their education programme includes a session called 'Water Watch' which is suitable for this topic. All sessions offered are free of charge.

[bit.ly/1Hyt3kX](https://bit.ly/1Hyt3kX)

#### London Wetland Centre

##### Queen Elizabeth's Walk, SW13 9WT

This area of lakes and ponds is not far from Hammersmith tube station, and can also be reached from Barnes train station. They have a number of suitable learning sessions you can book. If your school has more than 20% of students on free school meals, you could be eligible to visit for free.

[bit.ly/1gceIDK](https://bit.ly/1gceIDK)

#### Woodberry Wetlands

##### 1 Newton Close, N4 2RH

Due to open in 2015, this site near Hackney in North East London will have a visitor centre and walkways.

[bit.ly/1Kvc9WM](https://bit.ly/1Kvc9WM)

#### River Quaggy

An alternative London river, The River Quaggy flows for 17 kilometres through the boroughs of Bromley, Greenwich and Lewisham and joins the River Ravensbourne in central Lewisham in front of the station.

[bit.ly/1Kvc6dG](https://bit.ly/1Kvc6dG)

#### Lee Valley Trust

The Trust looks after a number of sites which are suitable for this topic, including the Bow Creek Ecology Park and East India Dock Basin (mentioned earlier) but also the Chingford and Walthamstow Reservoirs, River Lee Country Park (in Enfield) and Tottenham marshes.

[bit.ly/1HzBP49](https://bit.ly/1HzBP49)

#### Wandle Trust

Run a "Trout in the Classroom" project, but also offer guided walks along the river and lessons in the classroom focused on river processes and ecology in Merton and Sutton.

If none of these are possible, pond dipping could be carried out in a local park or even in the school playground.

[bit.ly/1LX3GJp](https://bit.ly/1LX3GJp)

# CONNECT

Students will produce a flyer, leaflet, short video or poster that can be used to explain what affects river ecosystems. This could be extended by considering human impact, and how our actions can improve our waterways.



## LESSON 5

### WHAT'S LIVING HERE?



#### BIG IDEA

The dynamic of ecosystems, with the interplay of biotic and abiotic factors; and human impact on ecosystems.



#### LEARNING OBJECTIVES

Could provide actions that humans can take to improve waterways like the River Thames

Should describe the impact of humans on waterways like the River Thames

Must describe the ecosystem in the River Thames and what affects it



#### RESOURCES

**Resource 5.1:** Suggested success criteria

#### YOU WILL ALSO NEED

- ◆ Film/voice recording equipment
- ◆ Computer and software for editing
- ◆ Paper and pens
- ◆ Internet access, for further research

#### MATHEMATICAL SKILLS

- ◆ Data handling and presentation

## LESSON 5: WHAT'S LIVING HERE?

### ACTIVITIES

#### STARTER

Introduce the task, which is to produce a flyer, leaflet, short video, podcast or poster that can be used to explain what affects river ecosystems, using the Thames as a focus. They could include audio, video and photos they gathered on their visit to enrich their presentations.

#### MAIN

Students create their flyer, leaflet, short video, podcast or poster. Students are assembled in to groups to work on these (ideally the same groups as they were in for the Explore). Before they start, decide on the success criteria. It would be good to get students to construct their own success criteria but Resource 5.1 (page 76) provides suggested criteria (and a guide for introducing the task).

They may wish to focus their presentation on one area of the Thames, such as the area nearest to the school or the area they visited in their Explore session.

The presentation content could be extended by considering human impact on the river, and how our actions can improve our waterways.

#### PLENARY

Students engage with what each other have produced, and peer assess in relation to the success criteria agreed at the start. (This could be done online, see below under Homework ideas.)

#### Homework idea

Students' completed video and audio can be uploaded to the school e-learning platform. Students can then be asked to watch/listen to each other's product, and provide comments and/or ratings related to the success criteria they were working towards.

#### Assessment questions

Adapt or extend questions based on the activity, and/or use the following examples:

1. What impact have humans had on the River Thames, both positive and negative? **Extend:** What impact do you think you have on the River Thames?
2. What do you think we as a school community can do to improve the quality of water in the Thames?
3. What one thing do you think you can change to make your impact on the River Thames more positive?

## LESSON 5: WHAT'S LIVING HERE?

### RESOURCE 5.1: SUGGESTED SUCCESS CRITERIA



#### Basic

- ◆ Clear (if film/sound) or legible (if written/drawn)
- ◆ About ecosystems in the Thames (or another river in London)
- ◆ Involves input from everyone in the group
- ◆ Describes at least one food chain
- ◆ Describes one cause and effect using the Thames' ecosystem

#### Competent

- ◆ Interesting and engaging for the viewer/listener/reader
- ◆ Includes relevant visuals or audio descriptions
- ◆ Describes food chains that make up a food web
- ◆ Describes the impact of changes on a food web, such as the introduction of a species or the removal of one
- ◆ Describes predator-prey relationships

#### Mastery

- ◆ Includes visuals or audio from your visit, and perhaps even key findings
- ◆ Describes symbiotic and parasitic relationships
- ◆ Discusses the effect of humans on the Thames' ecosystem
- ◆ Uses historical examples to explain how human actions improved the Thames' ecosystem

## LINKS TO OTHER LONDON CURRICULUM SUBJECTS

### The River Thames STEM theme

This unit is part of a set of three exploring the technology and science of the River Thames.

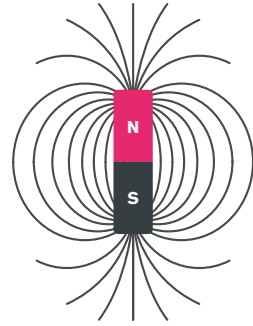
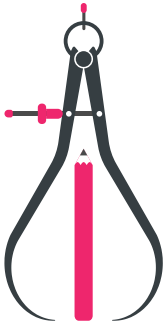

### DESIGN & TECHNOLOGY SCIENCE – PHYSICS

Bridging the river explores the design and technology of some of the most iconic bridges in the world.

The force of the river covers forces and pressure in the context of the working life and flood defences of the river.

## LINKS TO OTHER LONDON CURRICULUM SUBJECTS

### The River Thames in other subjects

The River Thames features in a number of other London Curriculum subjects, creating the possibility of a cross curricular visit.

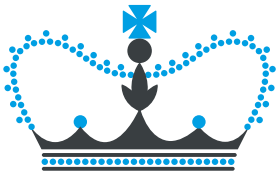

#### ENGLISH

Tales of the River explores the Thames in writing, as a metaphor for writers' hopes and fears and the city itself.

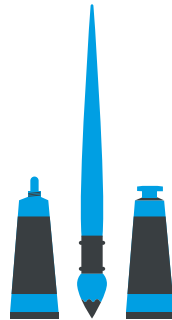

#### ART & DESIGN

Riverscape features the dynamic life of the River Thames captured in art



#### MUSIC

Global City explores the musical impact of London's global and maritime history.



## CREDITS

The GLA would like to thank the following organisations for their contribution:

Our collaborators on  
the London Curriculum



Copyright

Greater London Authority  
June 2015

Greater London Authority  
City Hall  
The Queen's Walk  
London SE1 2AA

[www.london.gov.uk](http://www.london.gov.uk)  
enquiries 020 7983 4100  
minicom 020 7983 4458



'The idea of using London as a teaching resource has never been explored much before, so both students and teachers are excited about it'

**Key stage 3 teacher**

'It makes me feel proud to be a Londoner'

**Key stage 3 student**